

ARM LIT PREMIUM BANQUETTE - 160

Premium vertical wallbed 160 with Sofa
 Vertikales Schrankbett Premium 160 mit Sofa
 PREMIUM verticaal kastbed 160 met Bank

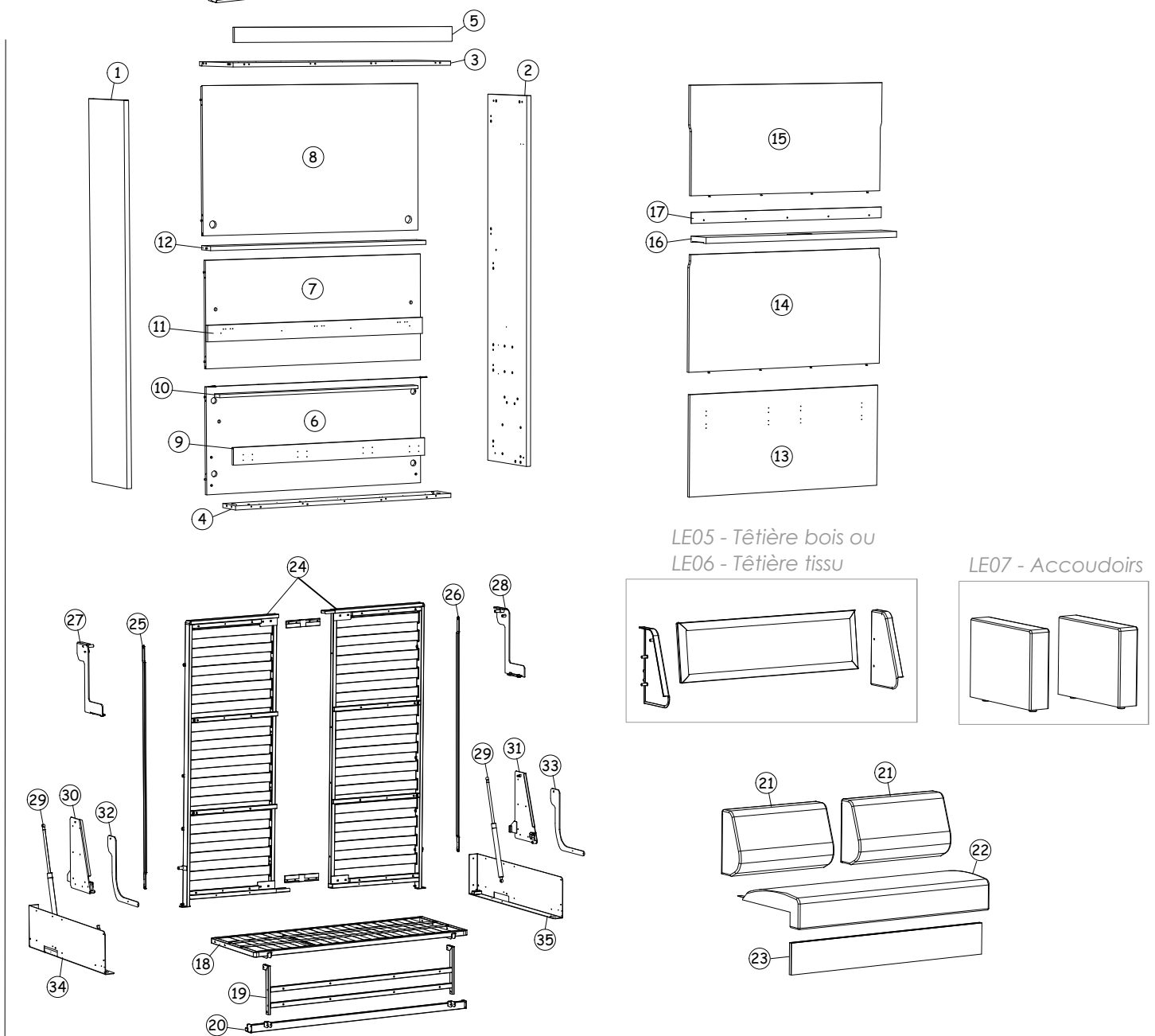
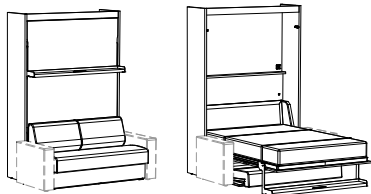

LE05 - Tête bois ou
 LE06 - Tête tissu

LE07 - Accoudoirs



Fonctionnement impératif de l'armoire-lit avec un matelas /
Only use the wallbed with a mattress /
Matratze für Funktionsweise des Schrankbetts erforderlich /
Voor het gebruik van het kastbed is een matras verplicht

IMPORTANT - A lire attentivement - A conserver
IMPORTANT - Read carefully - keep these instructions
WICHTIGER HINWEIS - Bitte aufmerksam lesen - Bitte aufbewahren
BELANGRIJK - Aandachtig lezen - Goed bewaren



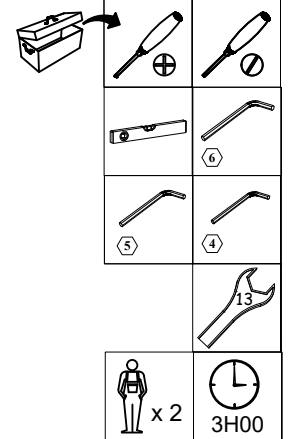
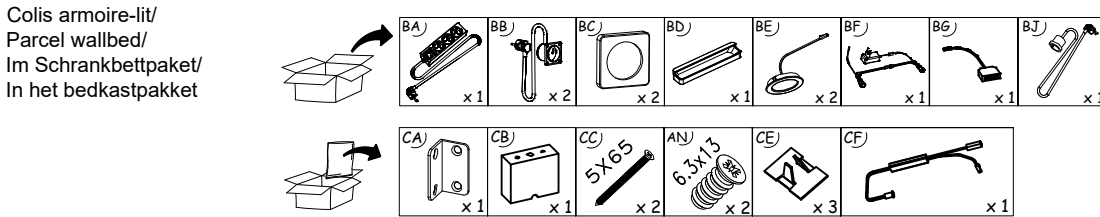
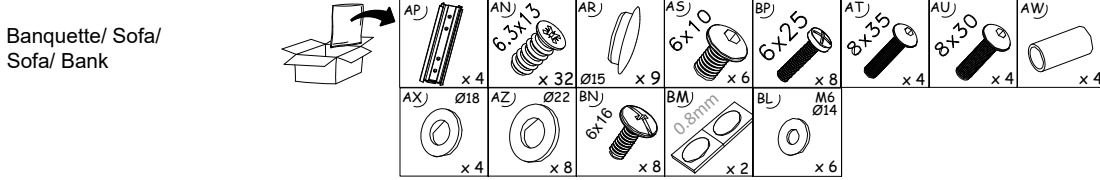
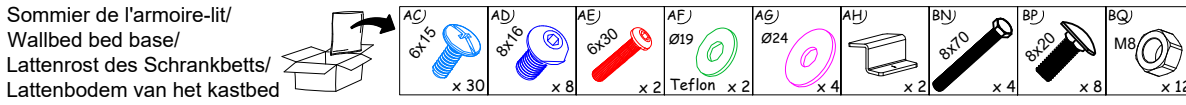
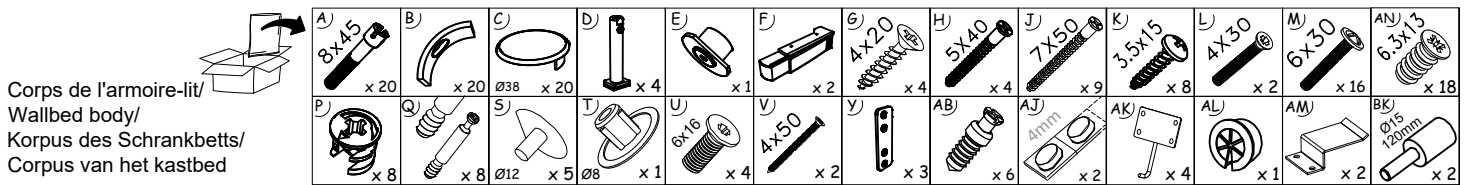

Les cotes indiquées sont en millimètres / Dimensions are given in mm // Alle Maße sind in mm angegeben / De opgegeven maten zijn in millimeter

<p>FR</p> <p>CONSEILS DE PREPARATION AU MONTAGE :</p> <ol style="list-style-type: none"> 1 : Repérez les pièces constituant le meuble. 2 : Regrouper et compter la quincaillerie. 3 : Munissez vous de l'outillage nécessaire. 4 : Aménagez vous une zone de montage ; la moquette ou une couverture protégera des rayures. 5 : Procédez au montage. Ne jamais forcer les assemblages. Resserez les vis après quelques temps d'utilisation. 6 : Gardez votre notice de montage, si une pièce venait à manquer, elle serait le moyen le plus clair pour communiquer avec votre magasin. 7 : Avant de jeter l'emballage, vérifiez s'il est bien vide. 	<p>CONSEILS D'ENTRETIEN :</p> <p>Dépoussiérer avec un chiffon sec et doux. Si besoin, passer une éponge humide, voire légèrement savonneuse, puis essuyer aussitôt avec un chiffon sec, propre et doux.</p> <p>EVITER :</p> <p>Les solvants, diluants, alcools, abrasifs et cire.</p> <p>NOTA : En cas de doute, faire un essai sur une partie peu visible du meuble.</p> <p>ATTENTION :</p> <p>Ne pas utiliser de produit ammoniacal pour le nettoyage des miroirs, et surtout éviter que le produit ne coule à l'extérieur.</p>
<p>GB</p> <p>PREPARATION ADVICE BEFORE ASSEMBLY :</p> <ol style="list-style-type: none"> 1 : Identify each part of the unit and where it goes before you start assembling. 2 : Keep all metal screws, fixtures and fittings in a box and check that you have the right quantity. 3 : Make sure you have all the tools you need. 4 : Prepare an assembly area: spread out a sheet or rug to stop panels getting scratched. 5 : Start assembly. Never force any components when assembling. Check screws from time to time and retighten if necessary. 6 : Keep this instruction booklet for future reference. It's the most useful way of identifying a missing part. 7 : Check that packaging is empty before throwing it away. 	<p>CARE INSTRUCTIONS:</p> <p>Clean using a soft, dry cloth. If necessary, clean with a damp sponge and slightly soapy water, then dry immediately with a soft, clean, dry cloth.</p> <p>DO NOT USE:</p> <p>Abrasive cloths, solvents, thinners, alcohol-based products or any other chemical solvents, and waxes. It is best to test any cleaning products on a small area first.</p> <p>WARNING:</p> <p>Do not use ammonia or ammonia-based products to clean mirrors. Do not let mirror-cleaner come into contact with any other part of the unit.</p>
<p>DE</p> <p>TIPPS ZUR VORBEREITUNG DER MONTAGE :</p> <ol style="list-style-type: none"> 1 : Verschaffen Sie sich einen Überblick über die mitgelieferten Teile. 2 : Überprüfen Sie die mitgelieferten Schrauben und Beschläge auf Vollständigkeit. 3 : Legen Sie passendes Werkzeug bereit. 4 : Richten Sie sich einen Platz für die Montage ein. Ein Teppich oder eine Decke schützt vor Kratzern. 5 : Beginnen Sie mit der Montage. Fügen Sie die Teile niemals gewaltsam zusammen. Ziehen Sie die Schrauben nach einiger Zeit nach. 6 : Bewahren Sie Ihre Montageanleitung auf. Sollte ein Teil fehlen, kann Ihnen diese beim Kontakt mit dem Kundenservice helfen. 7 : Vergewissern Sie sich, dass sich keine Teile mehr in der Verpackung befinden, bevor Sie sie entsorgen. 	<p>PFLEGEHINWEISE:</p> <p>Entfernen Sie Staub mit einem trockenen und weichen Tuch. Verwenden Sie bei Bedarf einen feuchten Schwamm mit einer milden Seifenlauge. Wischen Sie die Fläche nach der Reinigung sofort mit einem trockenen, sauberen und weichen Tuch nach.</p> <p>BITTE VERMEIDEN SIE:</p> <p>Abrasive Lösungsmittel, Verdüner, Alkohole und Wachs. HINWEIS: Sollten Sie Zweifel haben, testen Sie das Reinigungsmittel an einer unauffälligen Stelle.</p> <p>ACHTUNG:</p> <p>Bitte verwenden Sie für die Reinigung von Spiegelflächen keine ammoniakhaltigen Reinigungsmittel und achten Sie besonders darauf, dass das Mittel nicht mit anderen Teilen in Berührung kommt.</p>
<p>NL</p> <p>ADVIEZEN BIJ DE VOORBEREIDING VAN DE MONTAGE:</p> <ol style="list-style-type: none"> 1. Controleer of alle elementen van het meubel aanwezig zijn. 2. Verzamel en tel het beslag. 3. Zorg dat u het nodige gereedschap bij de hand heeft. 4. Maak een montagezone vrij. Gebruik de vloerbedekking of een deken om krassen te voorkomen. 5. Begin met de montage. Bij het assembleren nooit forceren. Draai de schroeven opnieuw aan nadat het meubel enige tijd in gebruik is. 6. Bewaar de montagehandleiding goed. Indien er een onderdeel ontbreekt, komt ze goed van pas om duidelijk met de winkel te communiceren. 7. Gooi de verpakking pas weg als u zeker weet dat ze leeg is. 	<p>ONDERHOUD:</p> <p>Afstoffen met een droge, zachte doek. Wrijf indien nodig schoon met een vochtige spons, eventueel met wat zeep, vervolgens meteen droogwrijven met een zachte, schone en droge doek.</p> <p>VERMIJD:</p> <p>Solventen, oplosmiddelen, schuurmiddelen op alcoholbasis en was. NB: Twijfelt u, test dan eerst op een weinig zichtbaar deel van het meubel.</p> <p>BELANGRIJK:</p> <p>Gebruik geen producten op ammoniakbasis om spiegels schoon te maken en vermijd absoluut dat het product naar buiten lekt.</p>

NOTE D'INFORMATION

et préconisations destinées aux installateurs concernant la fixation murale des armoires-lit

LA FIXATION MURALE DOIT ÊTRE RÉALISÉE OBLIGATOIREMENT PAR DES POSEURS QUALIFIÉS

1)

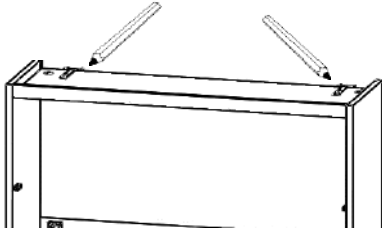

2)

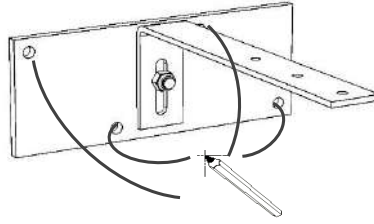

3) Mise en place chevilles

Les chevilles et les vis fournies sont préconisées pour les matériaux suivants:

- béton
- brique pleine
- brique creuse
- Plaque de plâtre épaisseur 12,5 mm, seulement si

les chevilles sont fixées dans le rail de plaque de plâtre.

Astuce: pour retrouver le rail derrière la plaque de plâtre, utiliser un aimant.

Bien souffler dans les trous

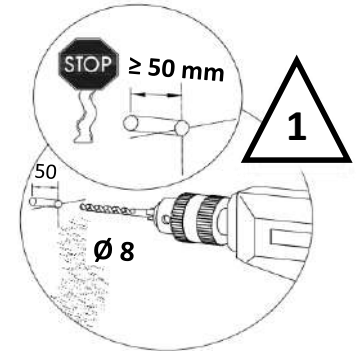

Pour les autres matériaux, utiliser des chevilles adaptées au mur

(se référer aux caractéristiques techniques préconisées par les fabricants de chevilles)

⚠ Pour les matériaux de type plaque de plâtre en contre cloisons et cloisons alvéolaires:

NE JAMAIS SE FIXER DIRECTEMENT SUR LA CLOISON.

Pour cela utiliser des chevilles longues traversantes pour se fixer sur le matériau porteur:

Cheville diamètre 8 mm de longueur 100 à 120 mm

et vis bois diamètre 5 ou 6 longueur 90 à 120 mm



4) Vissage de la platine

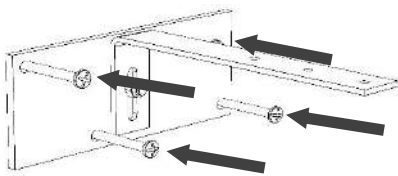

Centrer l'équerre par rapport à la platine mais ne pas bloquer l'écrou sur l'équerre, celle-ci doit pouvoir bouger lors du réglage de l'armoire-lit.

Veillez à ne pas créer de tensions sur les équerres.

La fixation ne doit pas contrarier l'assise de la caisse au sol.

L'avant du meuble doit **toujours être en appui très ferme sur le sol (utiliser les pieds réglables)**

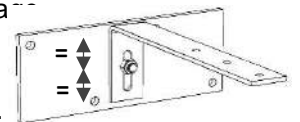

ATTENTION CHACUNE DE CES PLATINES DOIT RESISTER à 72,5 KG à L'ARRACHEMENT

C'est à dire que chaque vis de fixation au mur doit résister à 18,2 kg à l'arrachement

NE PAS SE FIXER SUR UN AUTRE MEUBLE

AVERTISSEMENT

Nos armoires-lit sont des produits de haute technicité dont la mise en œuvre nécessite des précautions importantes pour la sécurité des utilisateurs.

C'est pourquoi, seul un technicien qualifié peut procéder aux opérations de montage, réglage, équilibrage et démontage.

Il est particulièrement important de vérifier la nature et la qualité du sol et du mur auxquels l'armoire-lit sera fixée.

Si les conditions ne sont pas remplies, **on doit impérativement s'abstenir d'effectuer le montage.**

Le choix des types de chevilles et vis, ainsi que la méthode de perçage pour la fixation murale de l'armoire-lit sont fonction de la nature et de la qualité du mur et de ce fait, relèvent de la

SEULE RESPONSABILITÉ DU POSEUR

Après fixation des platines murales, le poseur devra obligatoirement vérifier la résistance à l'arrachement (72.5 kg par platine), à l'aide d'un dispositif de mesure adapté.

1

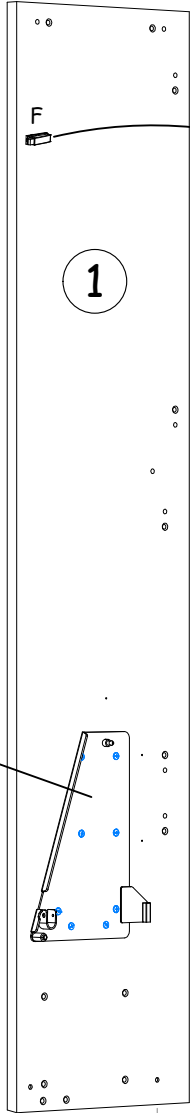

1

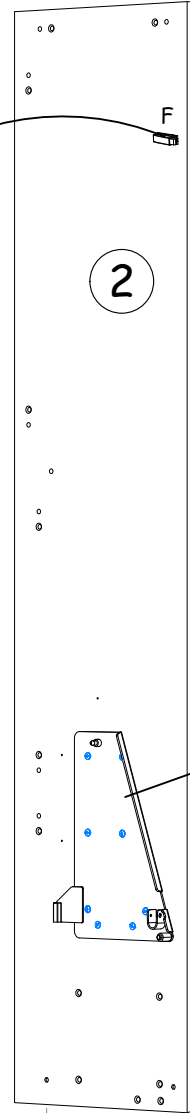
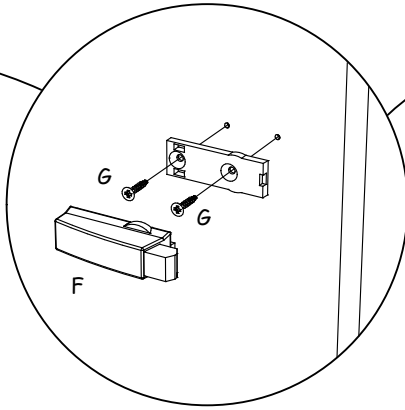

2

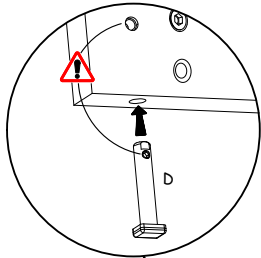

30

31

D D

D D

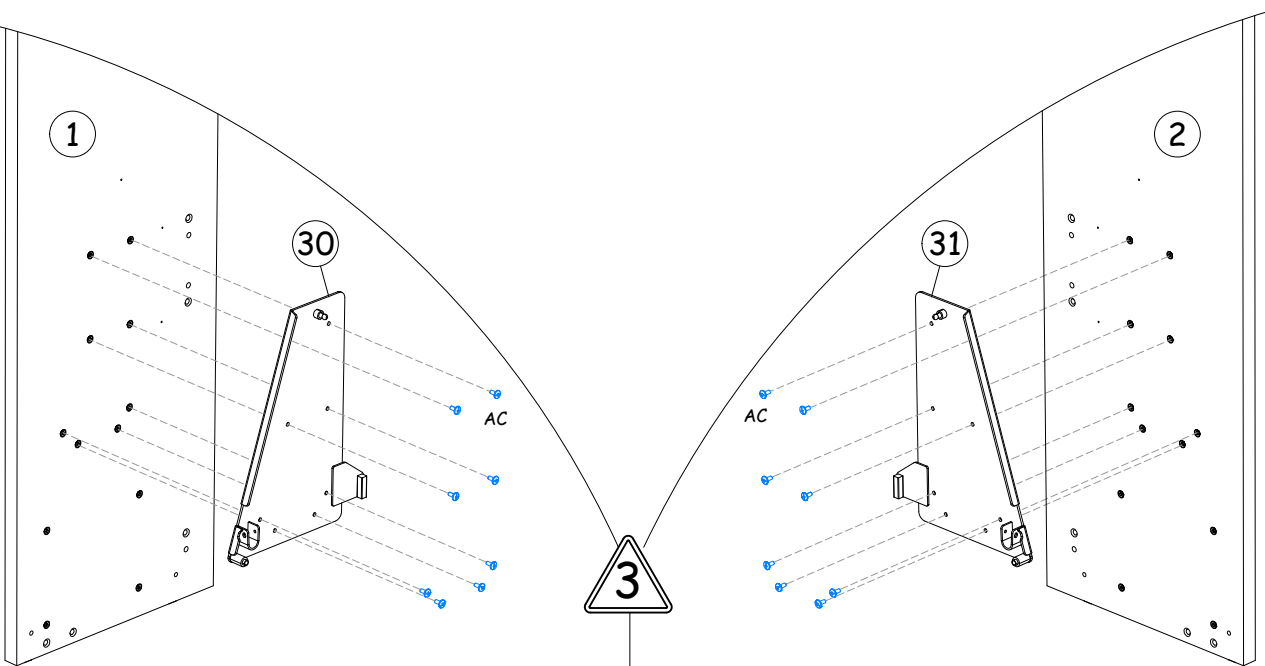

1

2

30

31

3

AC

AC

2

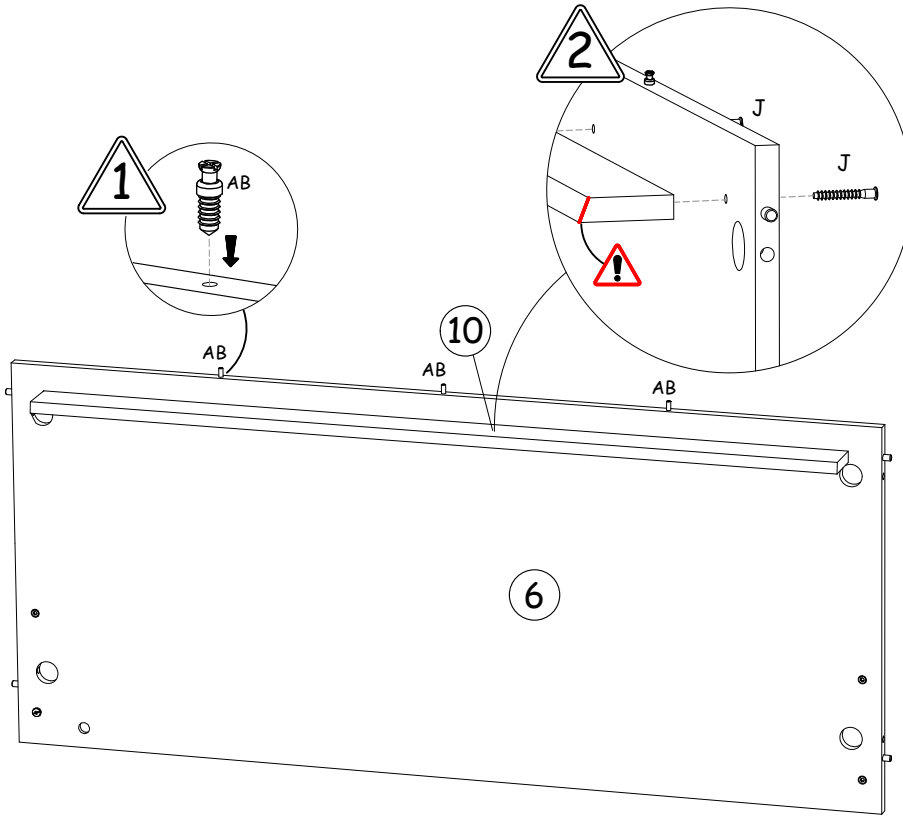

3

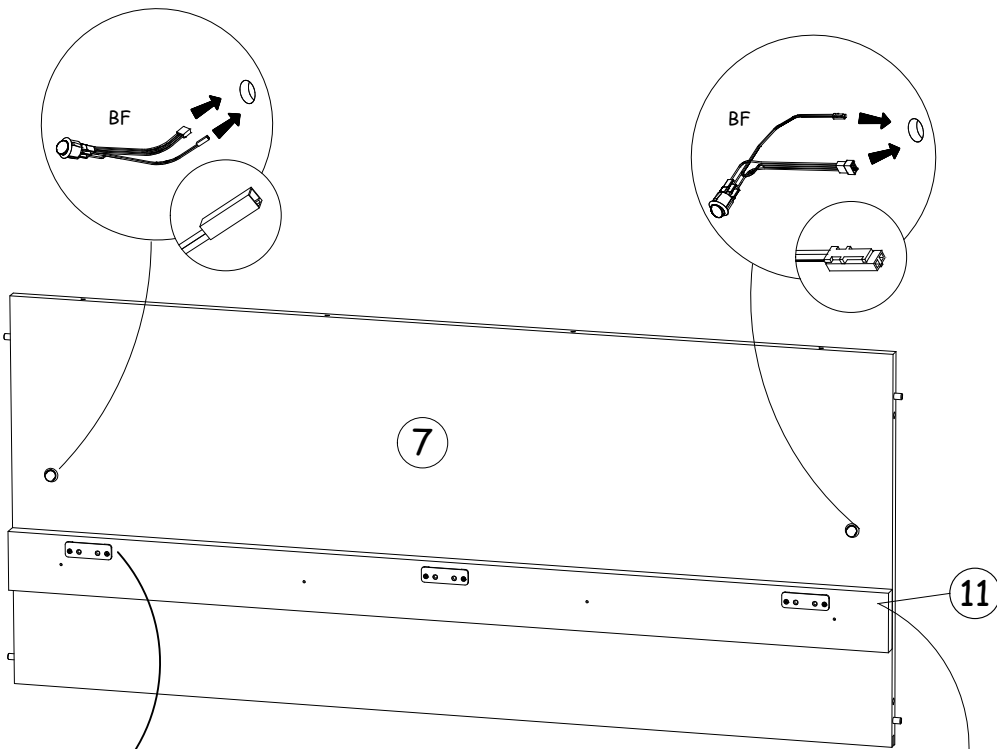

1

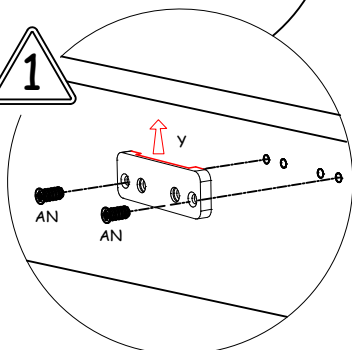

2

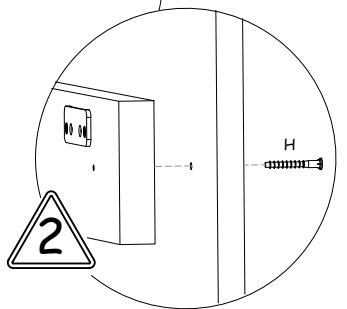

4

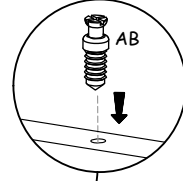
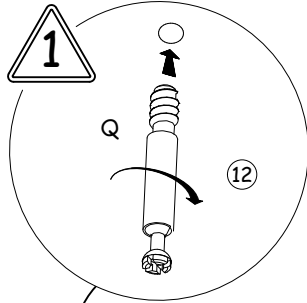

12

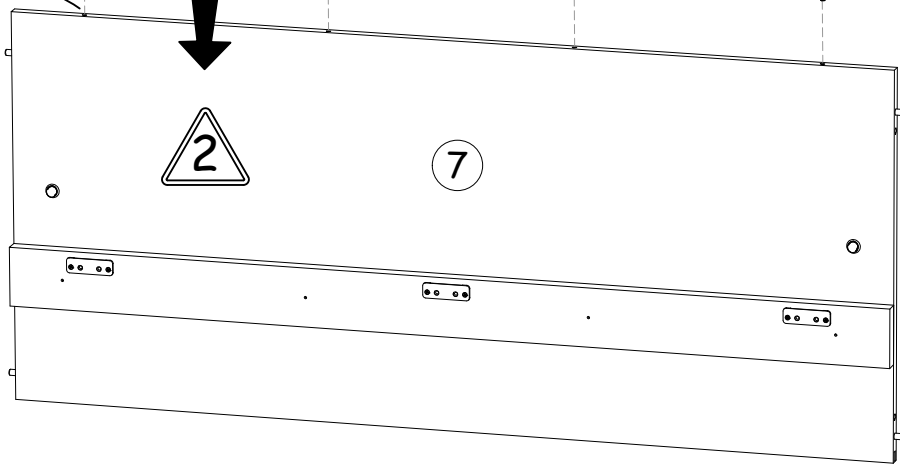
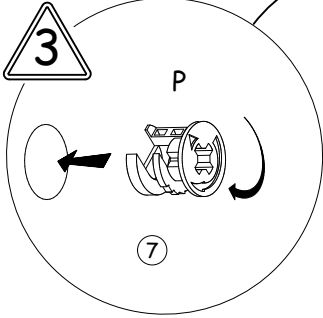
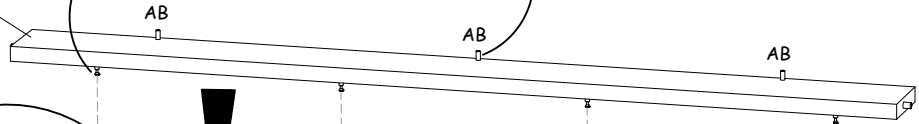

5

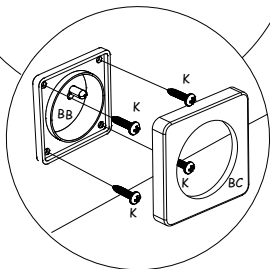
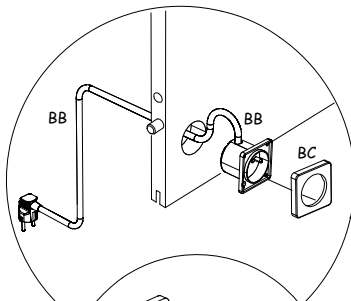
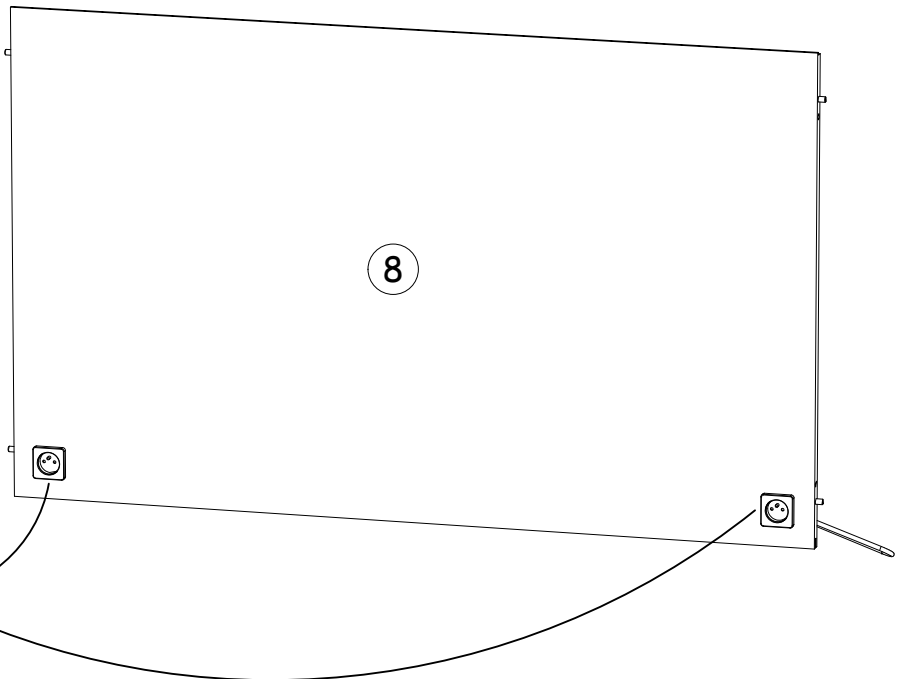

6

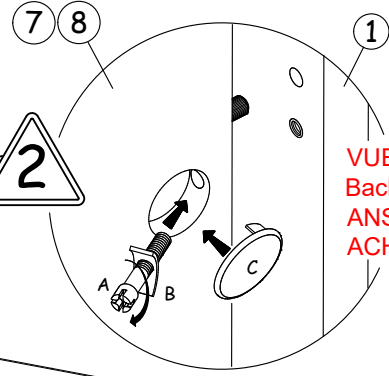
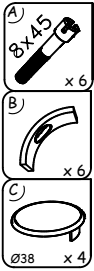

VUE ARRIERE /
Back view /
ANSICHT VON HINTEN /
ACHTERAANZICHT

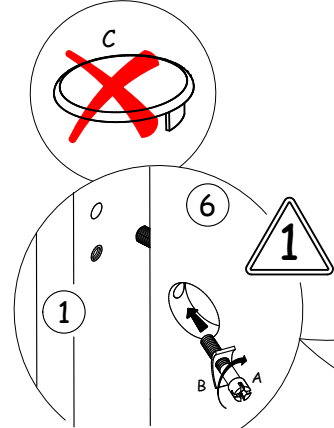

VUE DE FACE /
FRONT VIEW /
ANSICHT VON VORN /
VOORAANZICHT

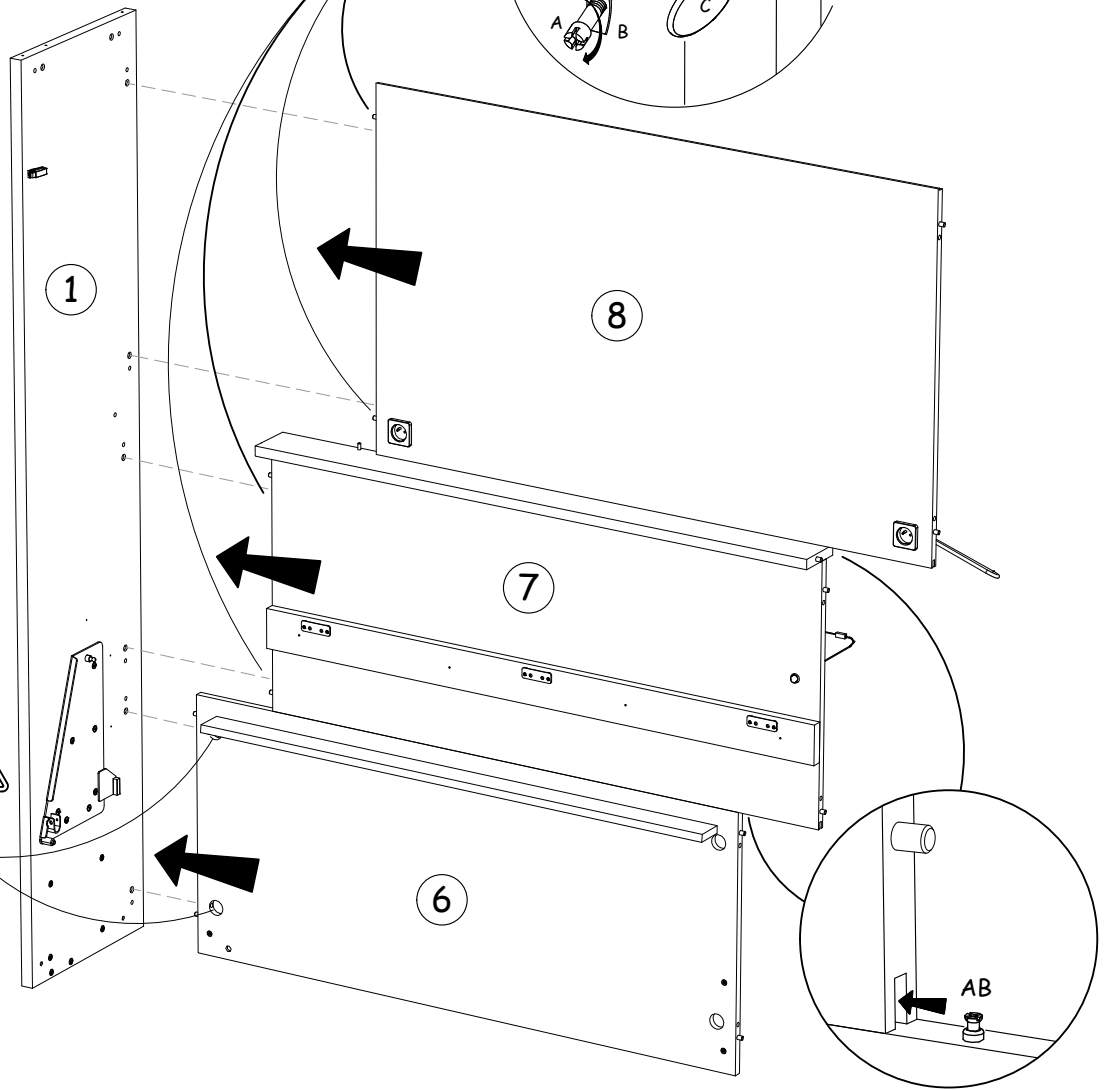

7

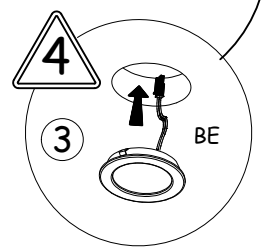
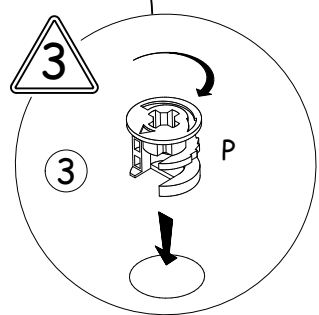
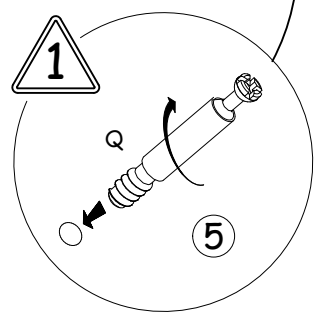
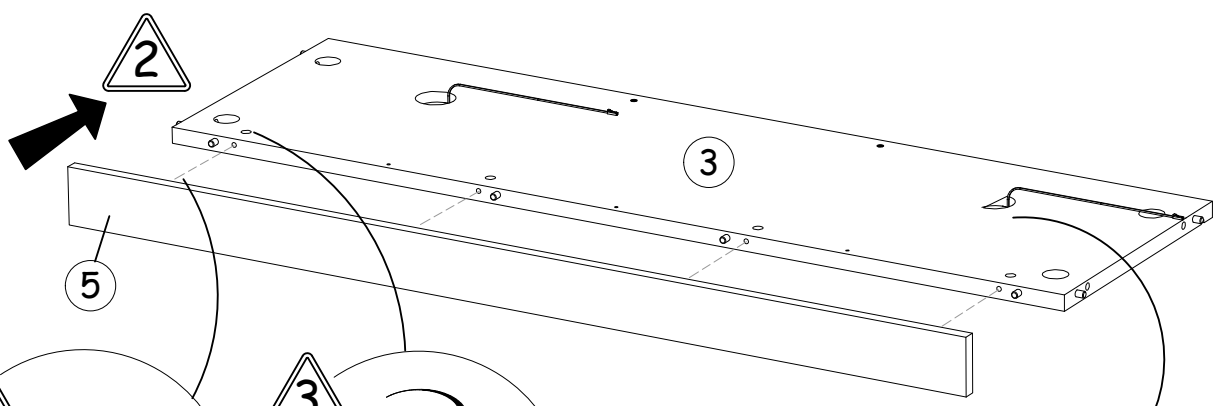
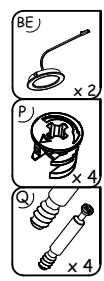

8



- A) x 2
- B) x 2
- C) x 2
- V) x 2

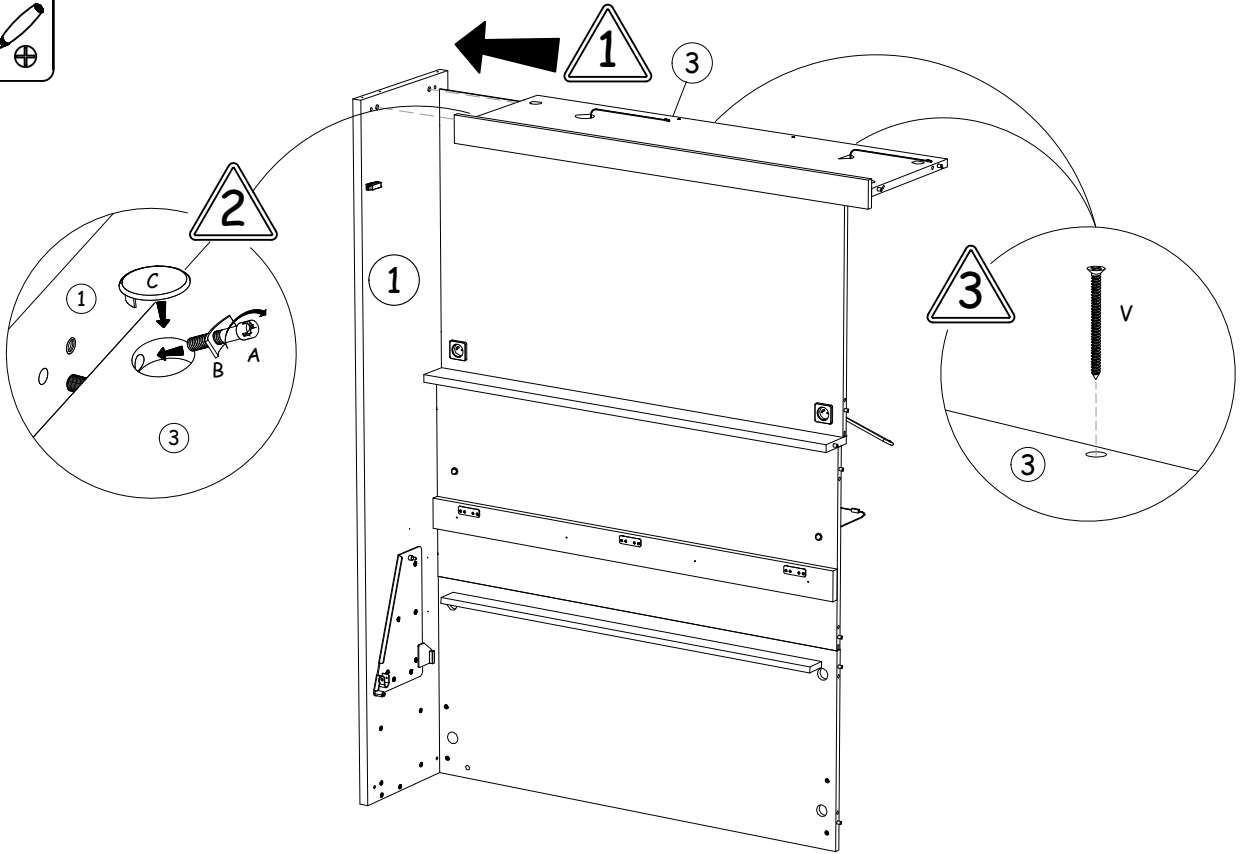

9



- A) x 8
- B) x 8
- C) x 6

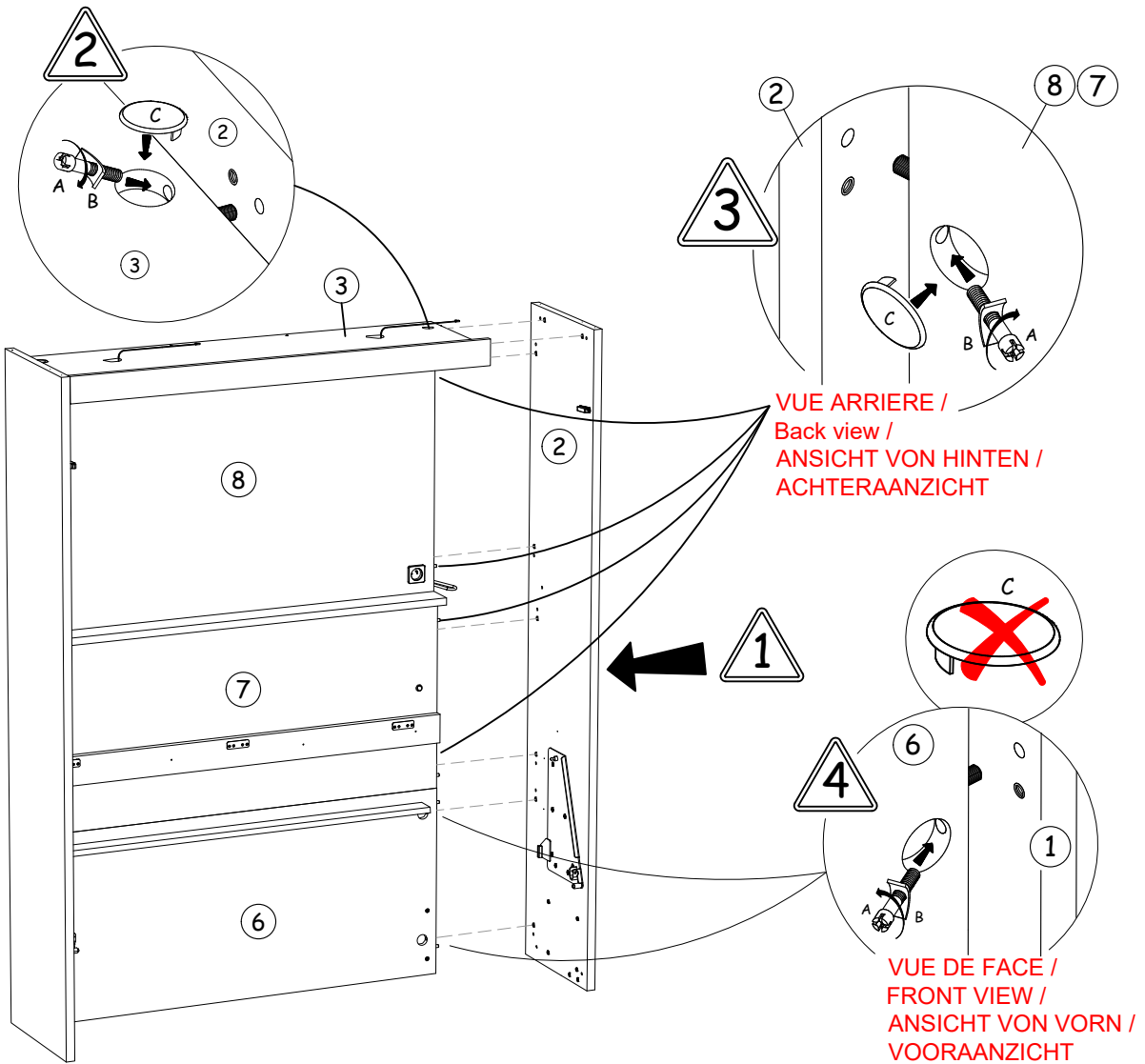

10

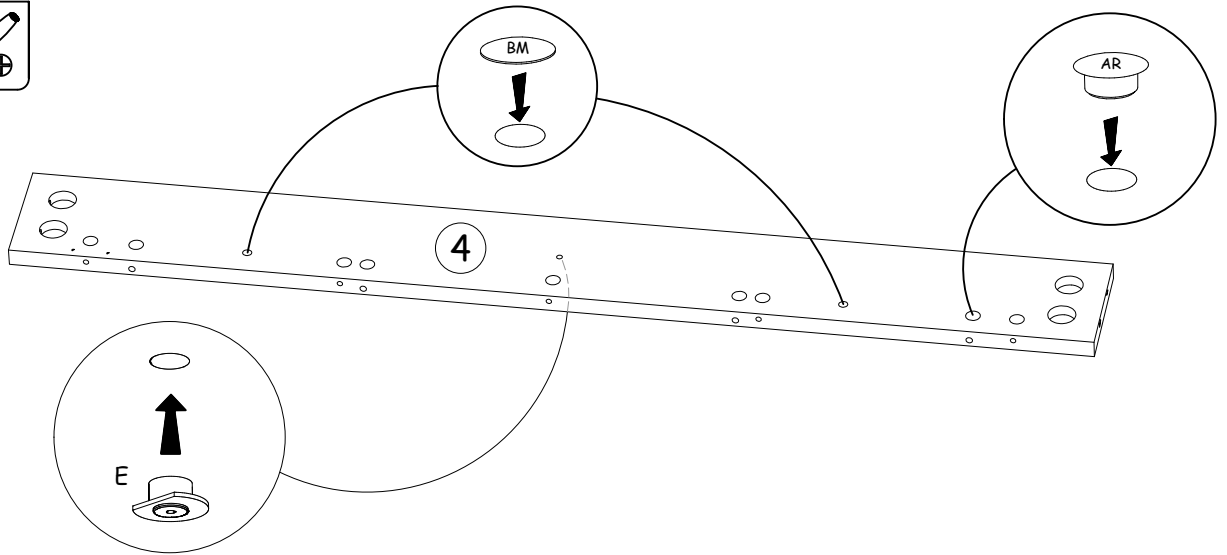
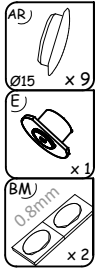

11

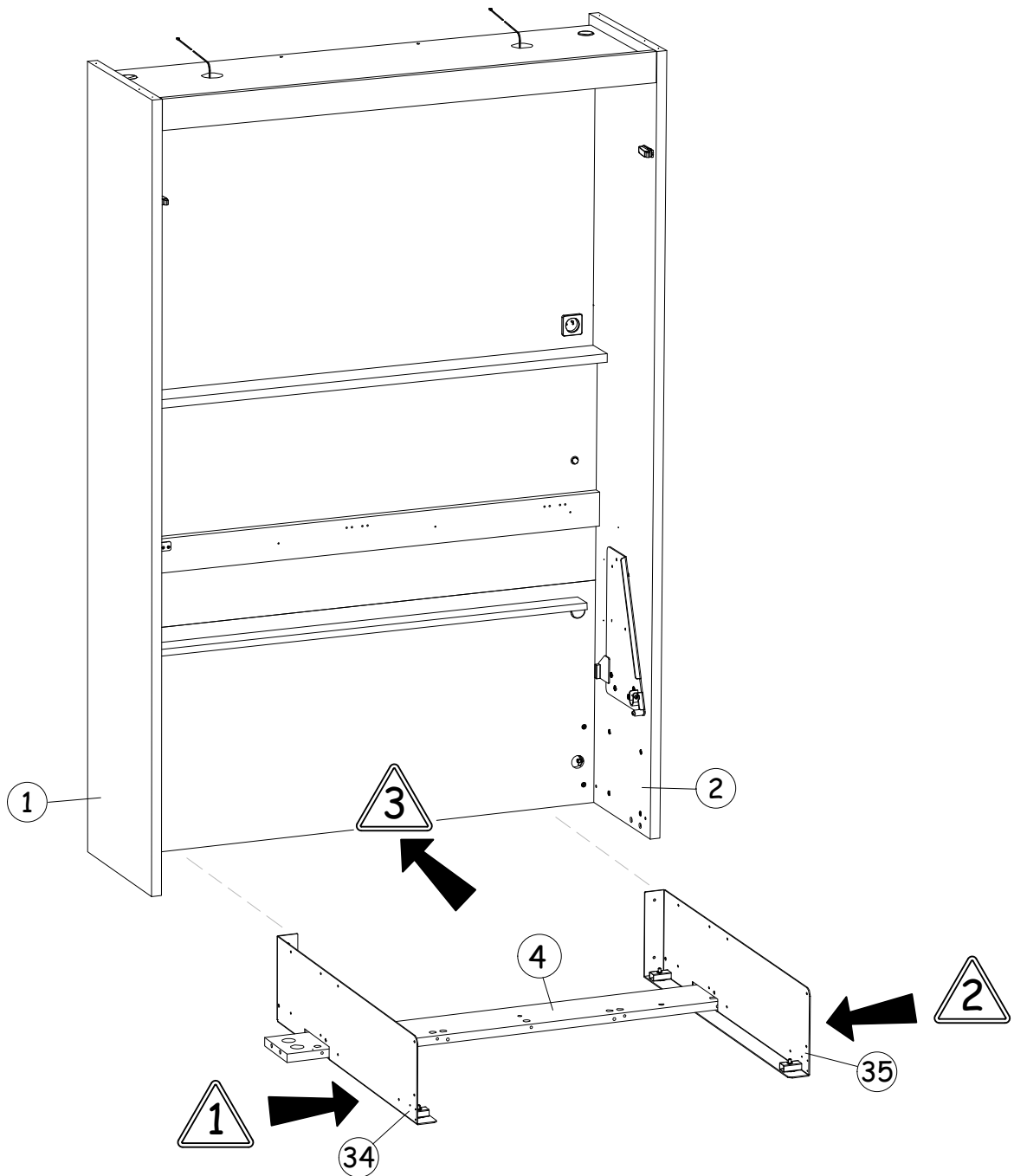

12

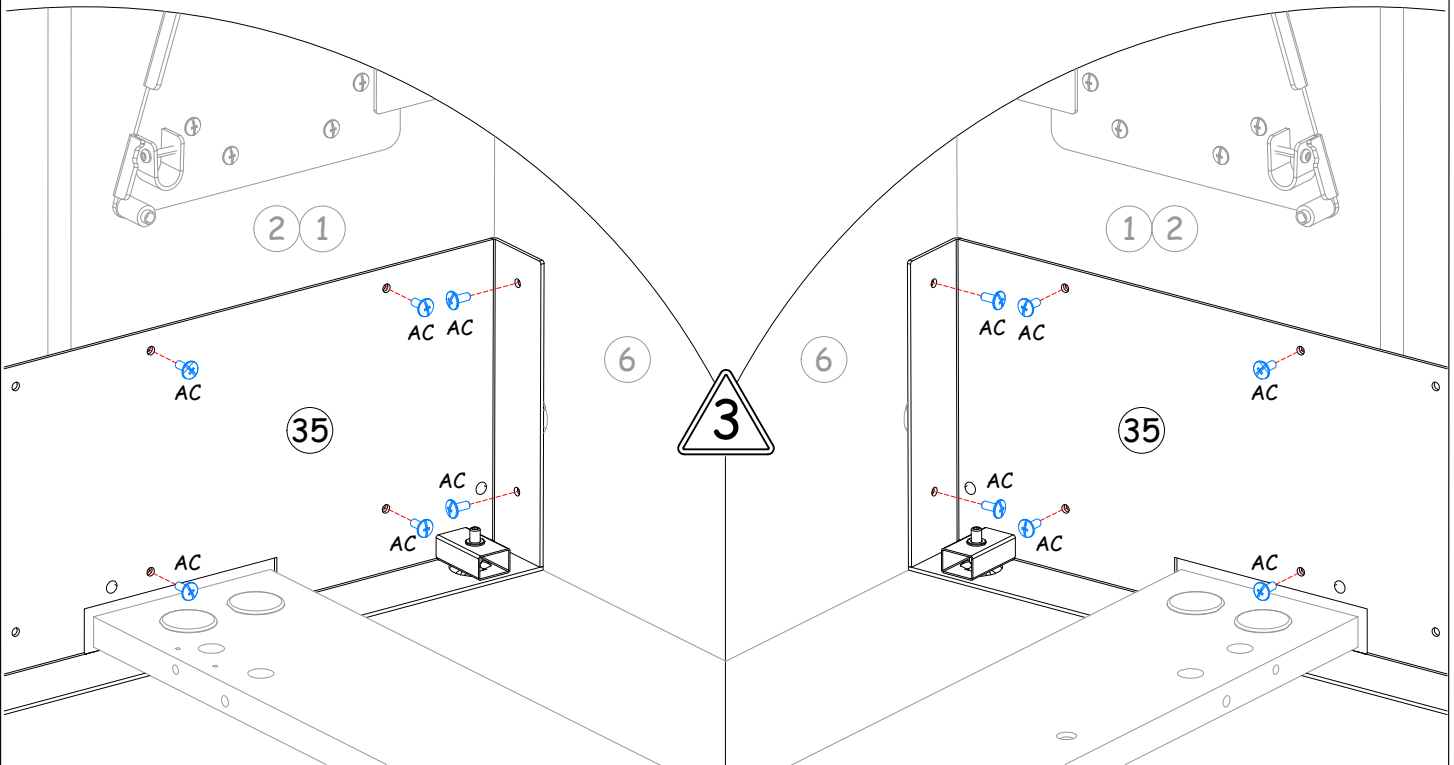
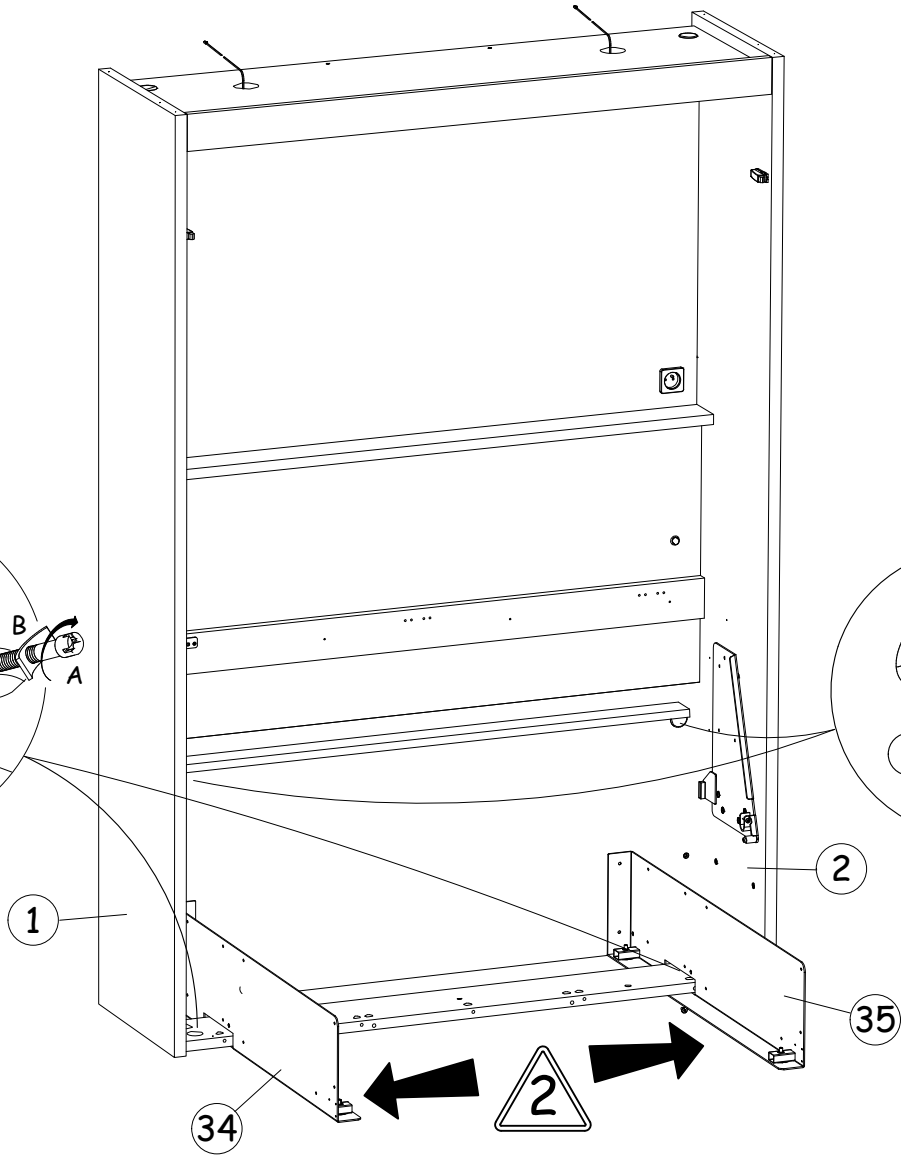
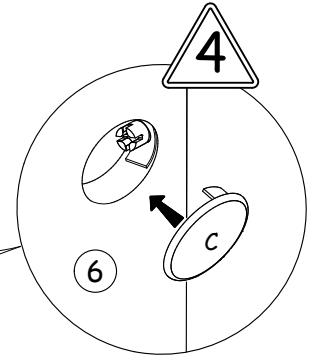
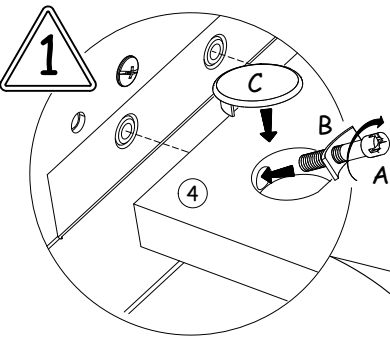

13

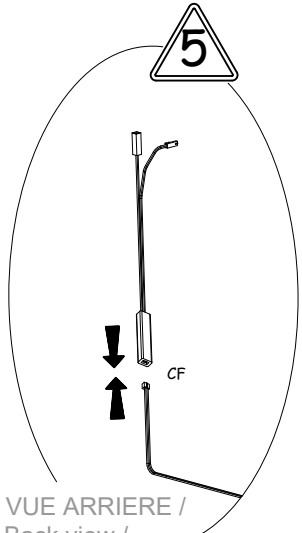
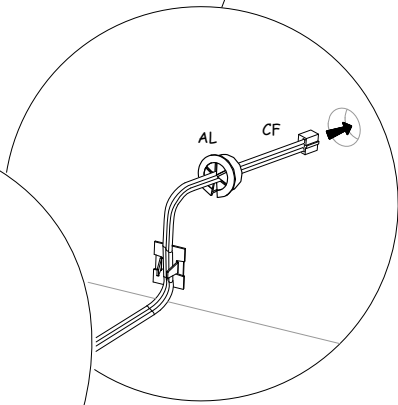
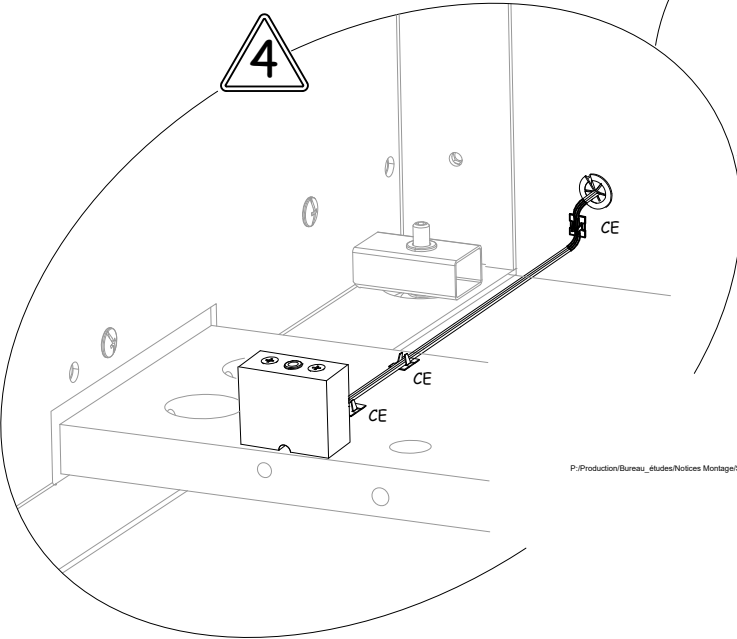
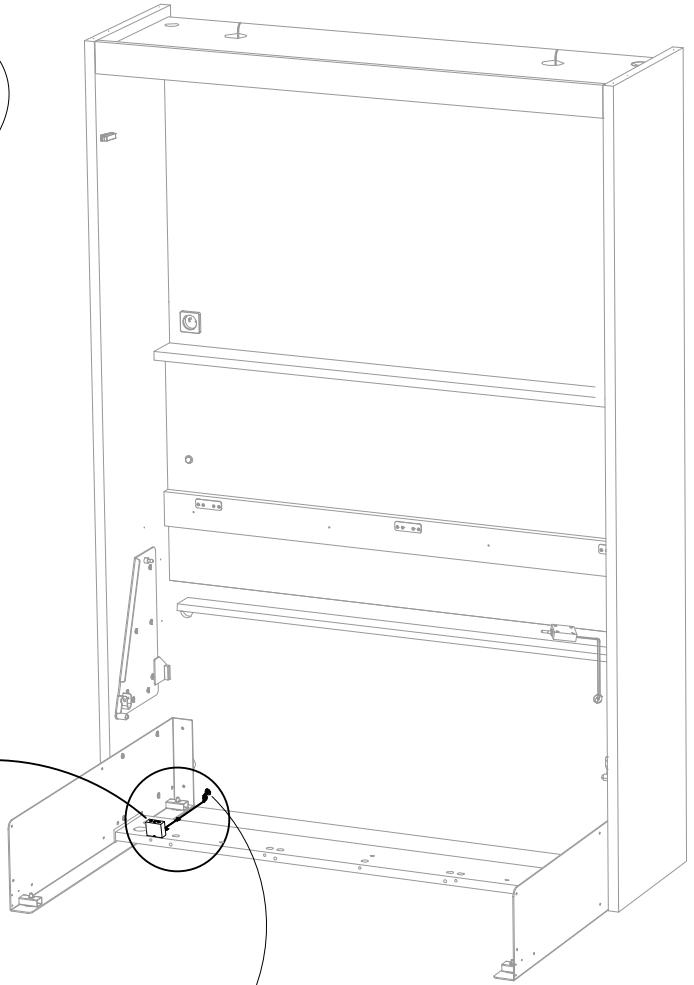
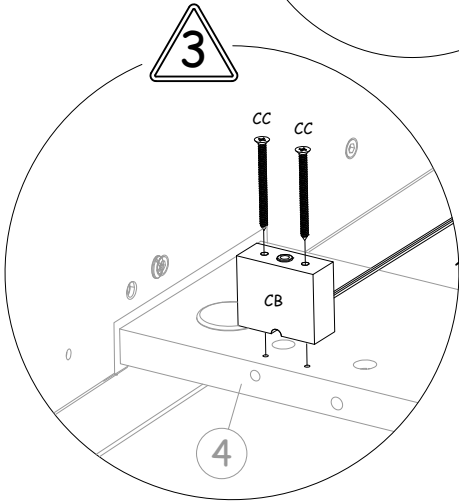
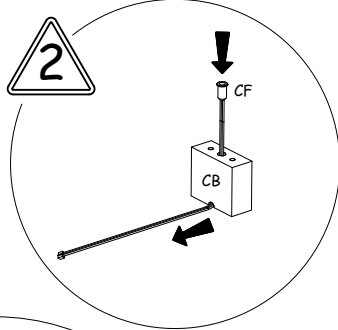
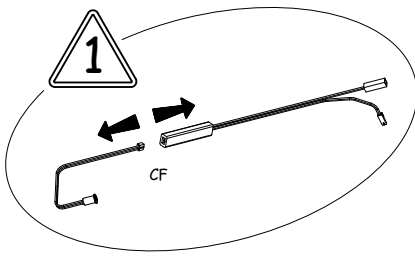
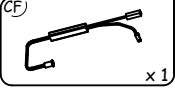

P:\Production\Bureau_etudes\Notices\Montage\SMART\Coupe circuit\Serre cable alu.png

VUE ARRIERE /
 Back view /
 ANSICHT VON HINTEN /
 ACHTERAANZICHT

14

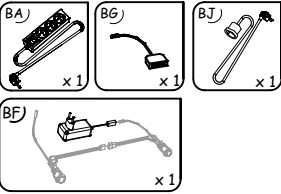

VUE ARRIERE /
Back view /
ANSICHT VON HINTEN /
ACHTERAANZICHT

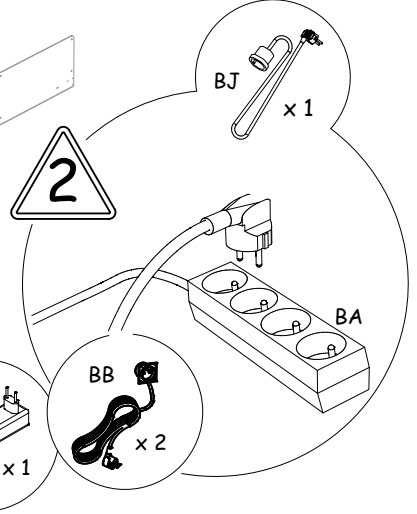
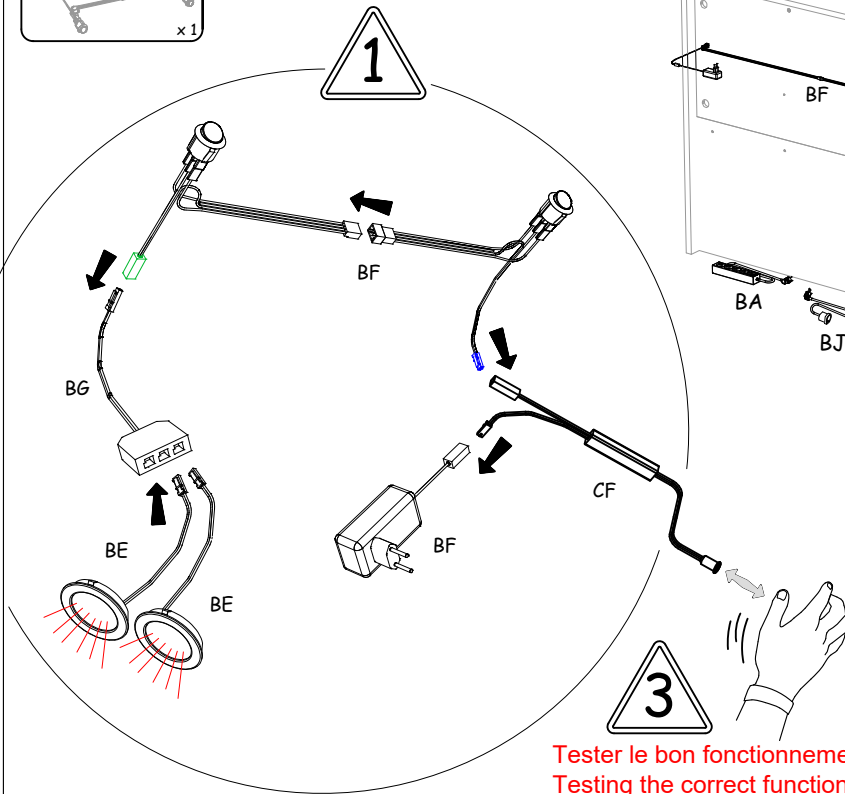
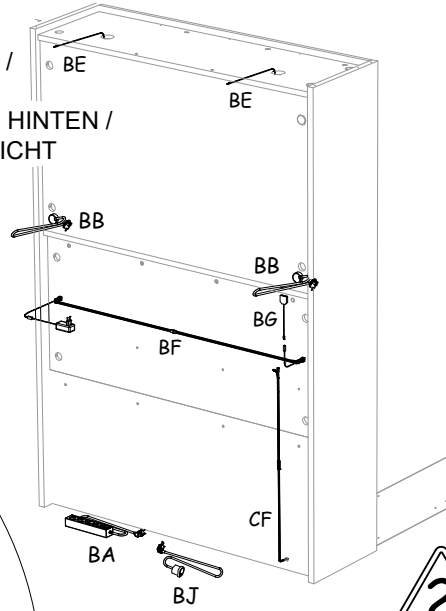

Tester le bon fonctionnement de l'éclairage et des interrupteurs /
Testing the correct functioning of the lighting and switches /
Die Funktionsfähigkeit der Beleuchtung und der Schalter testen /
Test of de verlichting en de schakelaars goed werken

15

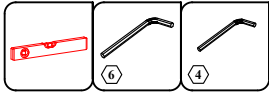

OK

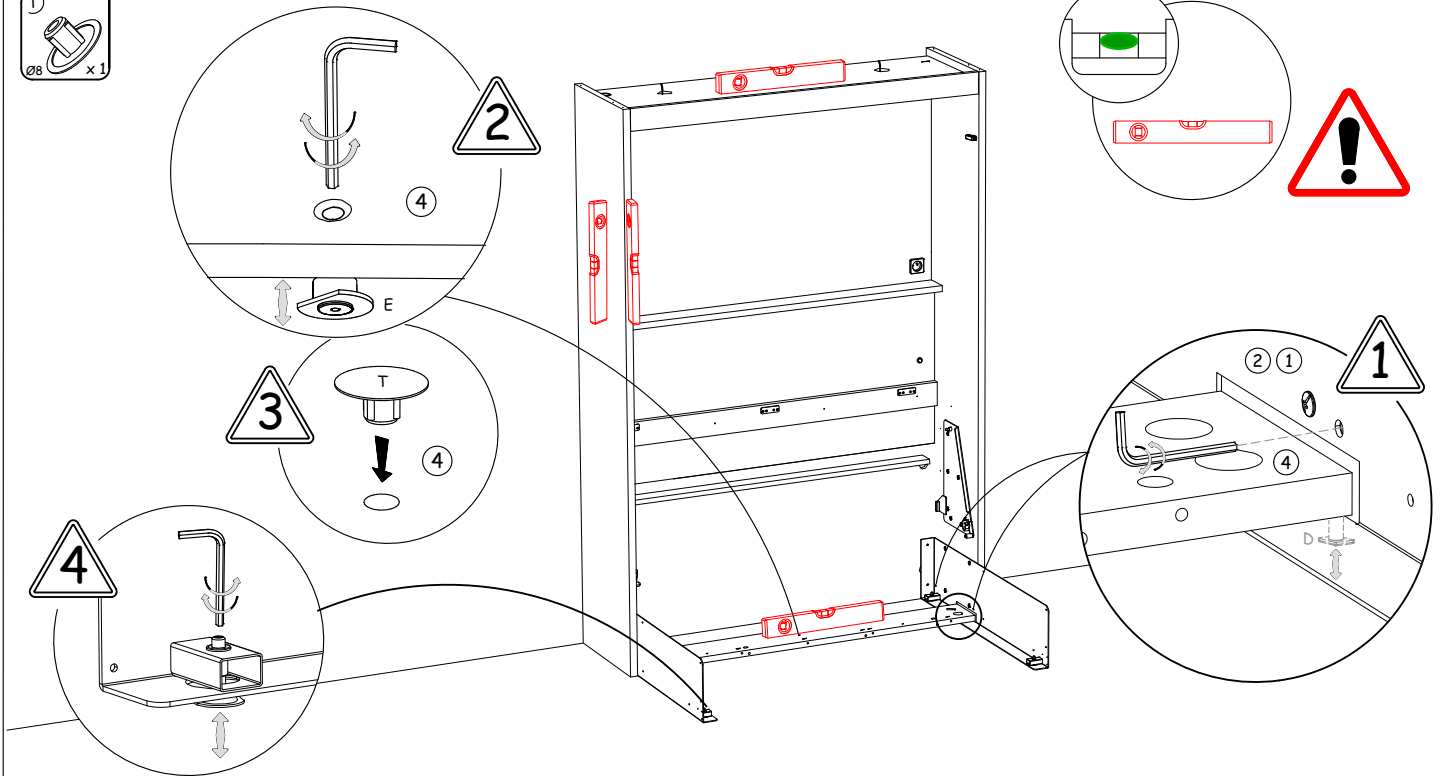

16

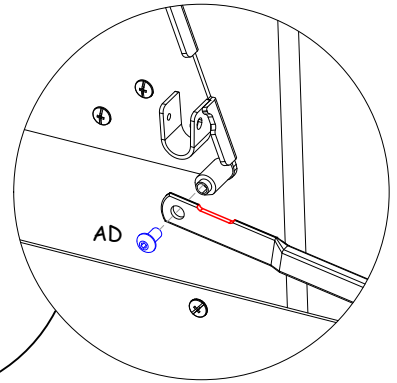
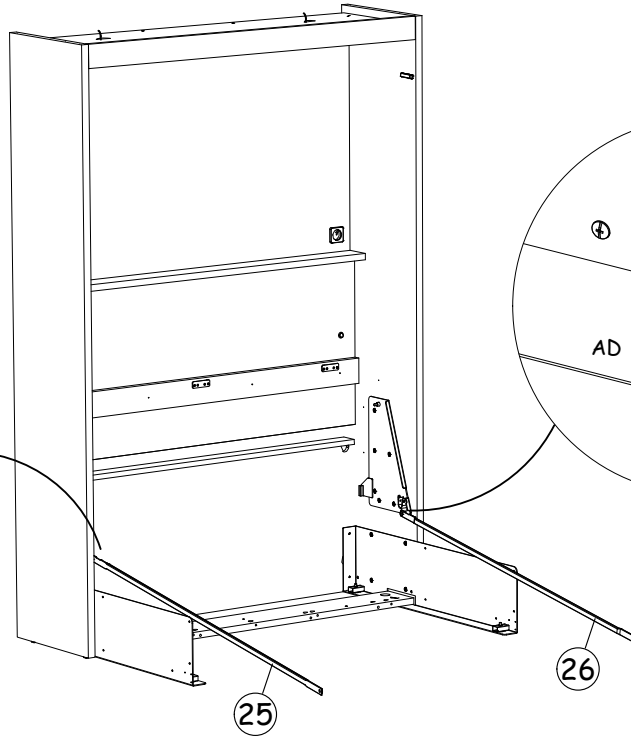
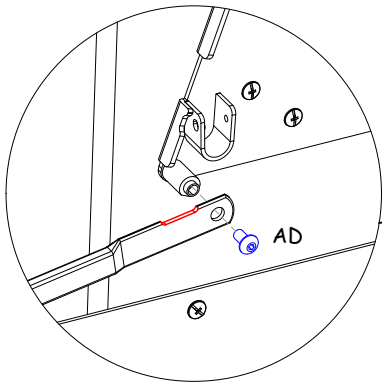

17

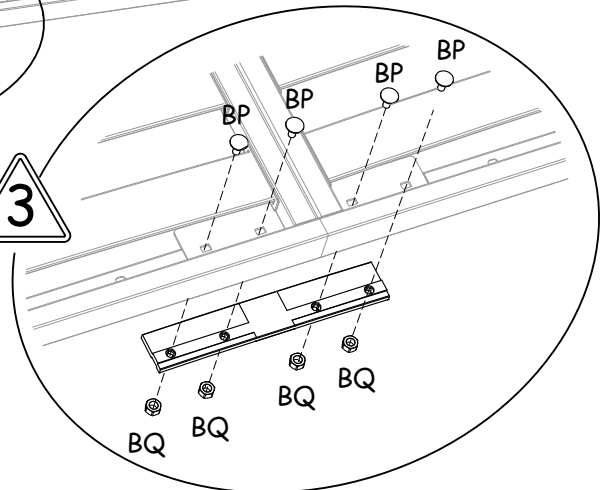
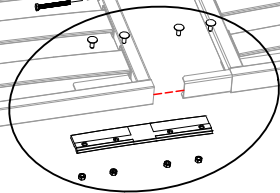
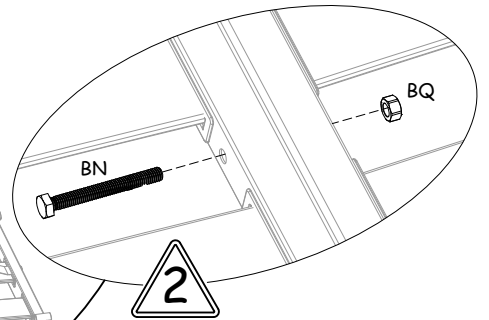
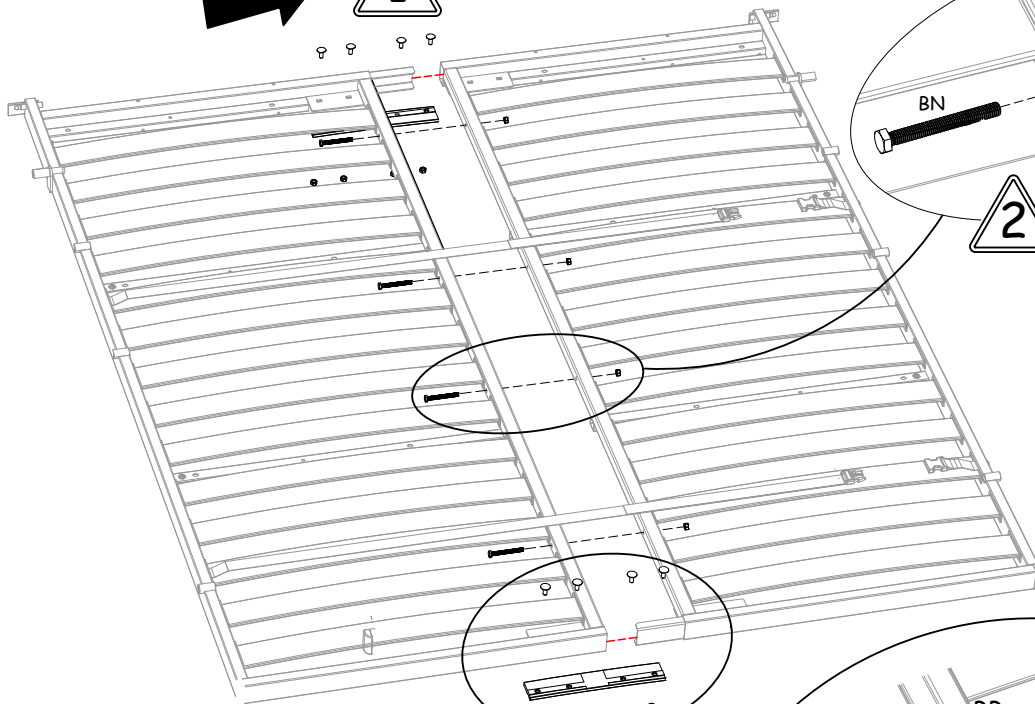

18

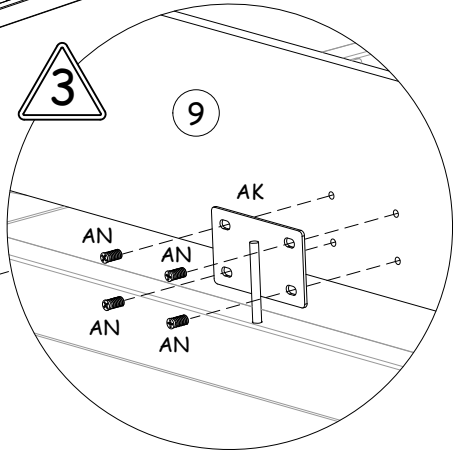
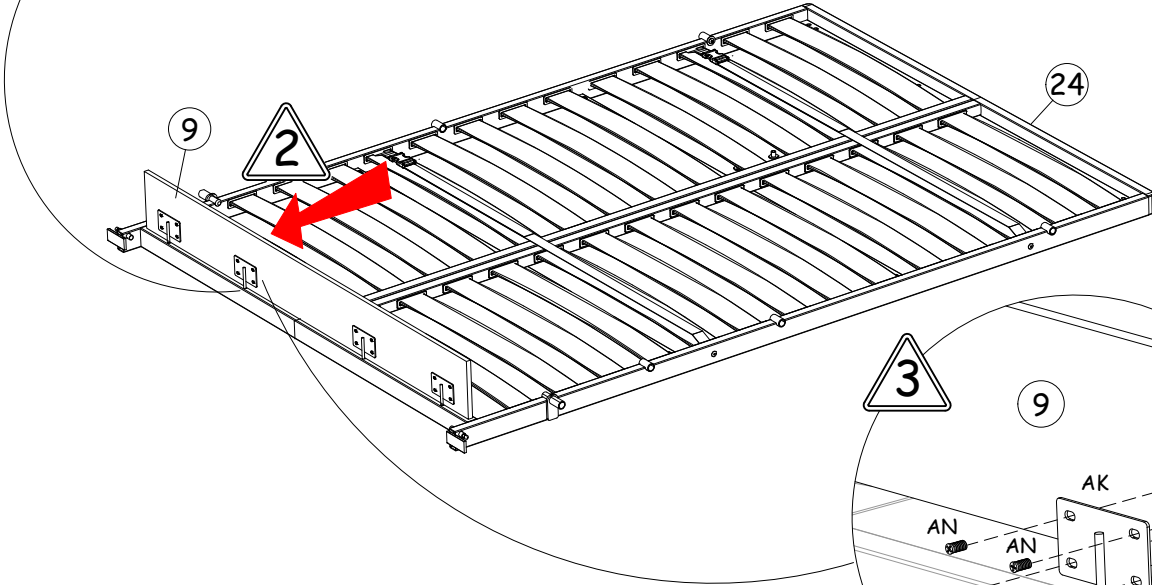
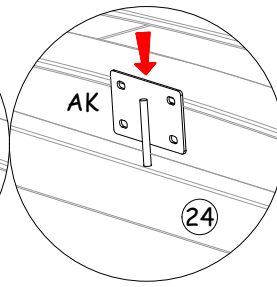
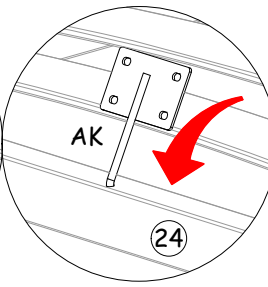
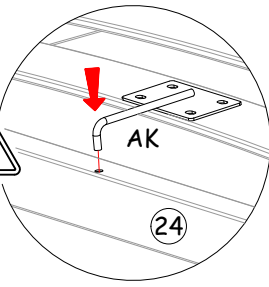

19



Contrôler / Control
/ Steuerung / Controle

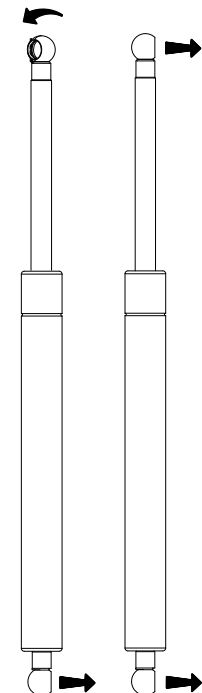
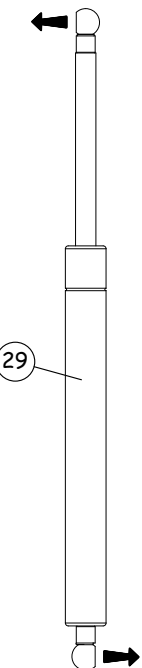

SECURITE
/ SAFETY SYSTEM
/ SICHERHEIT
/ VEILIGHEID

Déverrouiller la goupille
/ Unlock the pin
/ Den Stift entriegeln
/ De borgpen ontgrendelen

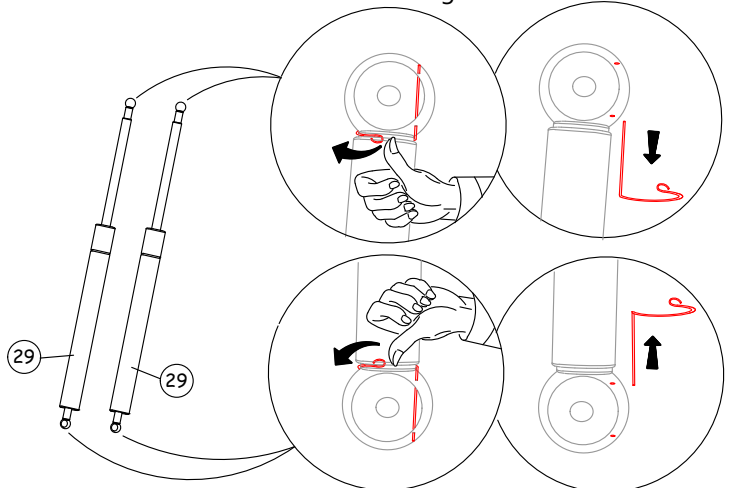

20

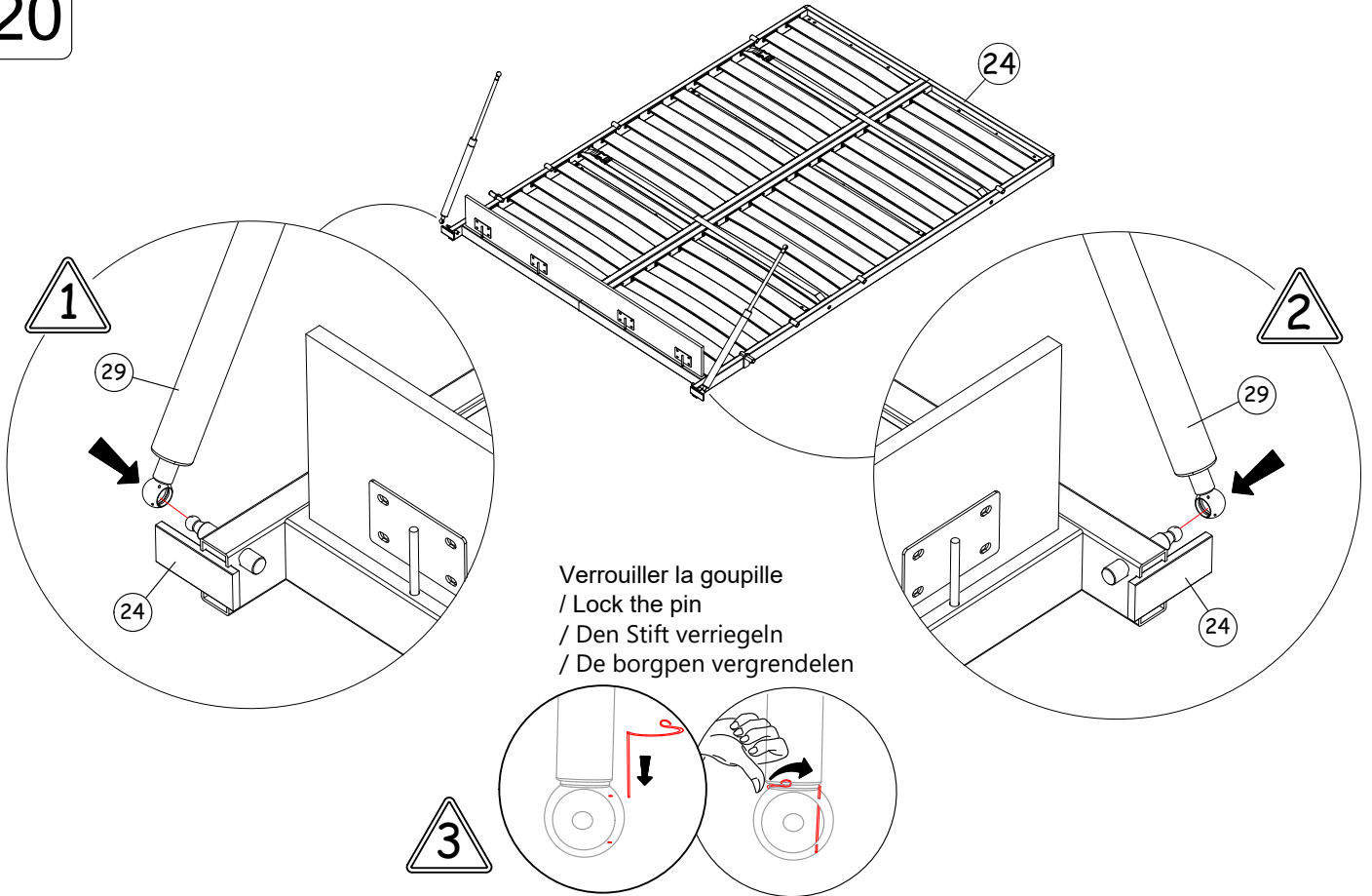

SECURITE / SAFETY SYSTEM / SICHERHEIT / VEILIGHEID

21

- AE
BX30
x 2
- AF
Ø19
Teflon x 2
- 4

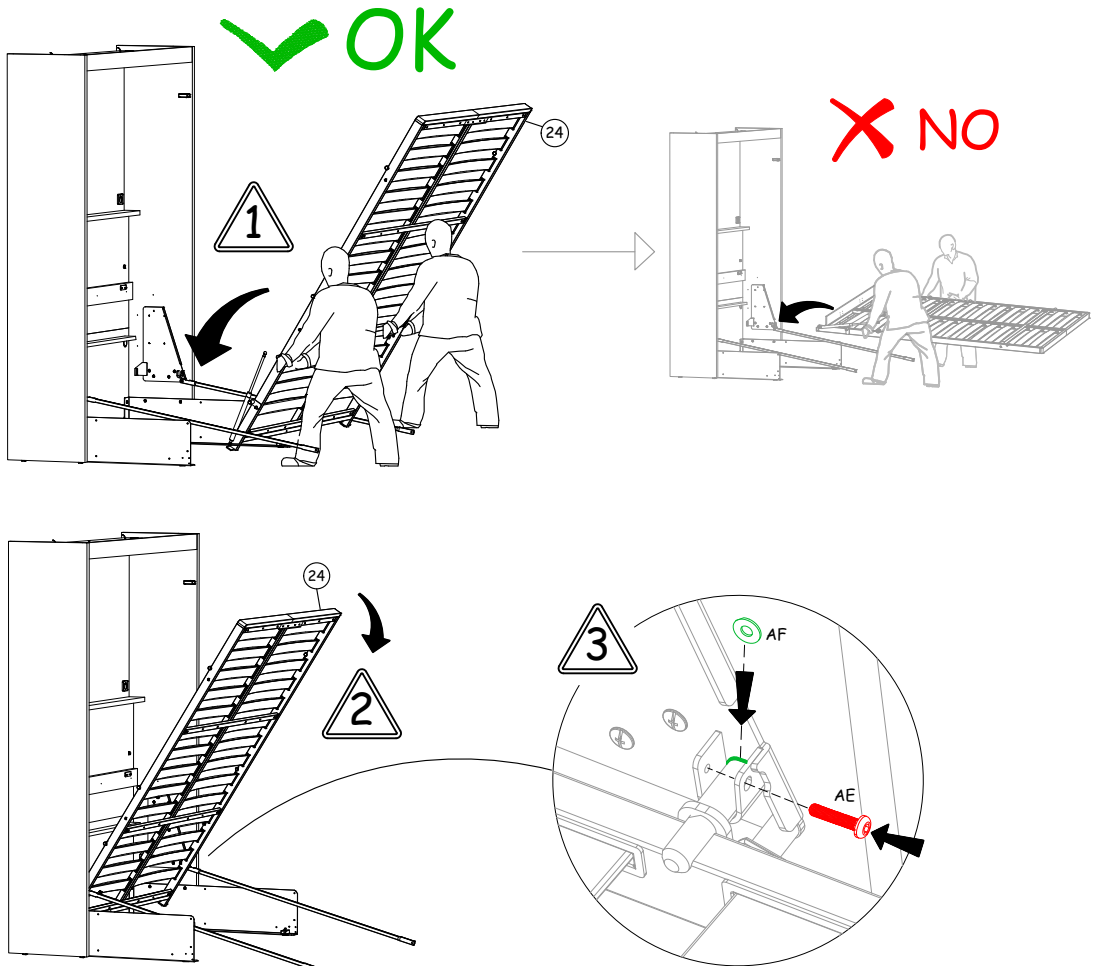

22

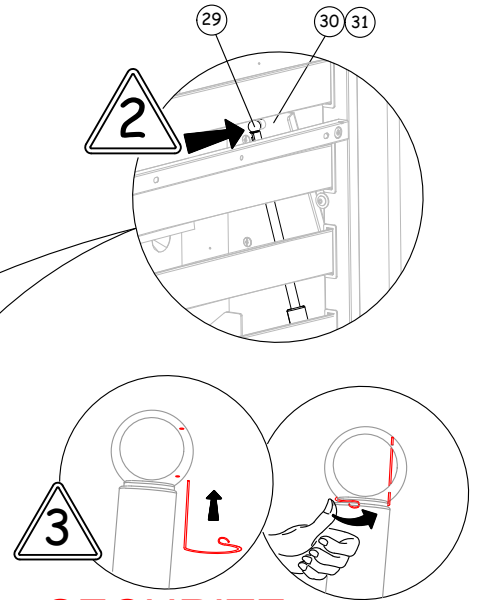
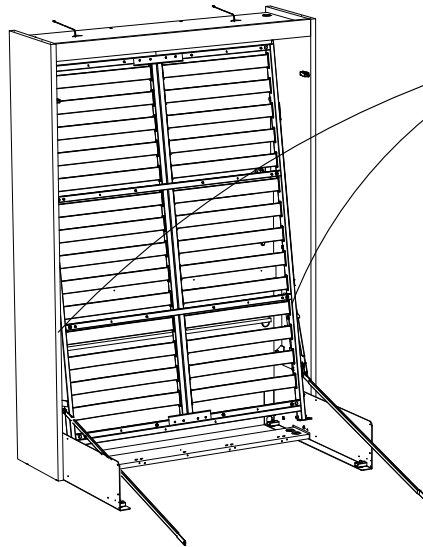
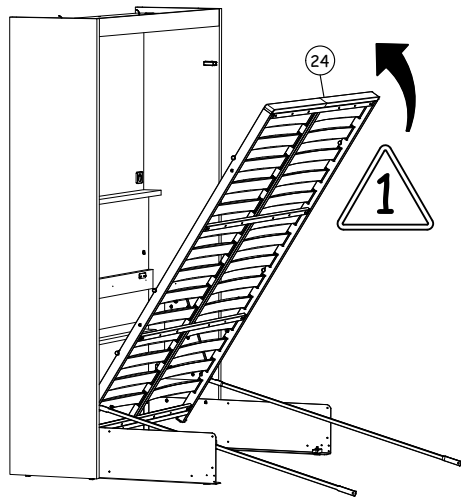

SECURITE
/ SAFETY SYSTEM
/ SICHERHEIT
/ VEILIGHEID

Verrouiller la goupille
/ Lock the pin
/ Den Stift verriegelen
/ De borgpen vergrendelen

23



✓ OK

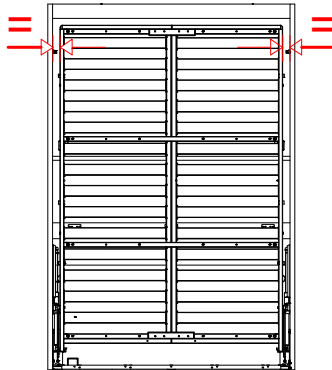

Contrôler / Control
/ Steuerung / Controle



✗ NO

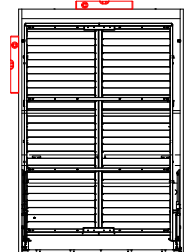
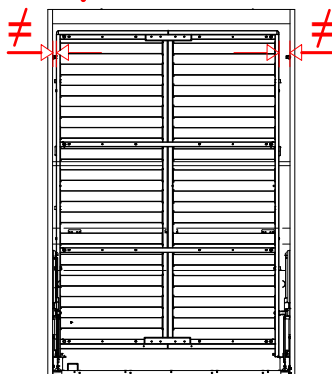

✓ OK

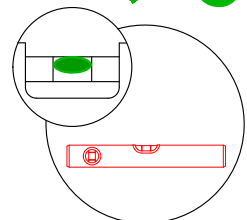

Si le jeu du sommier est inégal,
/ If the gap of the bed base is uneven
/ Wenn das Spalt der Bettbasis ungleichmäßig ist
/ BAs de bedbodem ongelijk is

24



Maintenir entre-ouvert
/ hold the wallbed half-open
/ halb geöffnet halten
/ halfopen houden

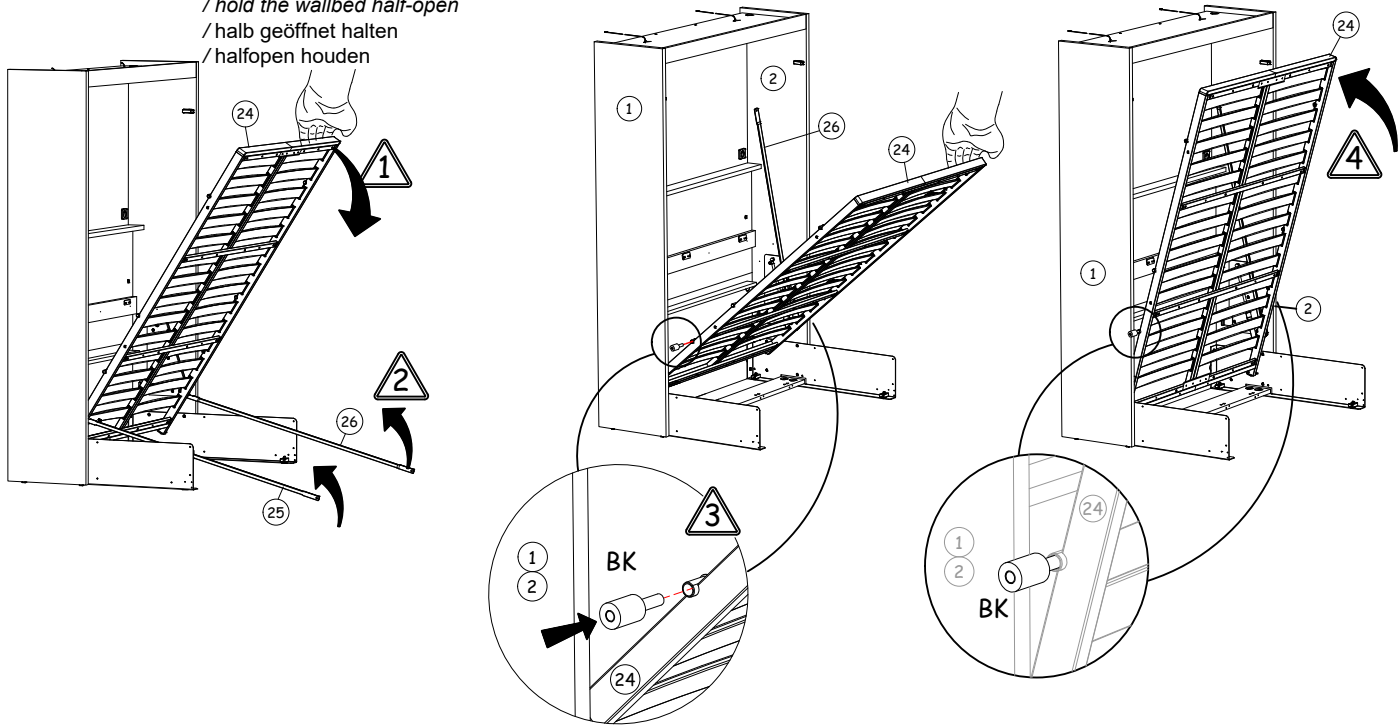

25

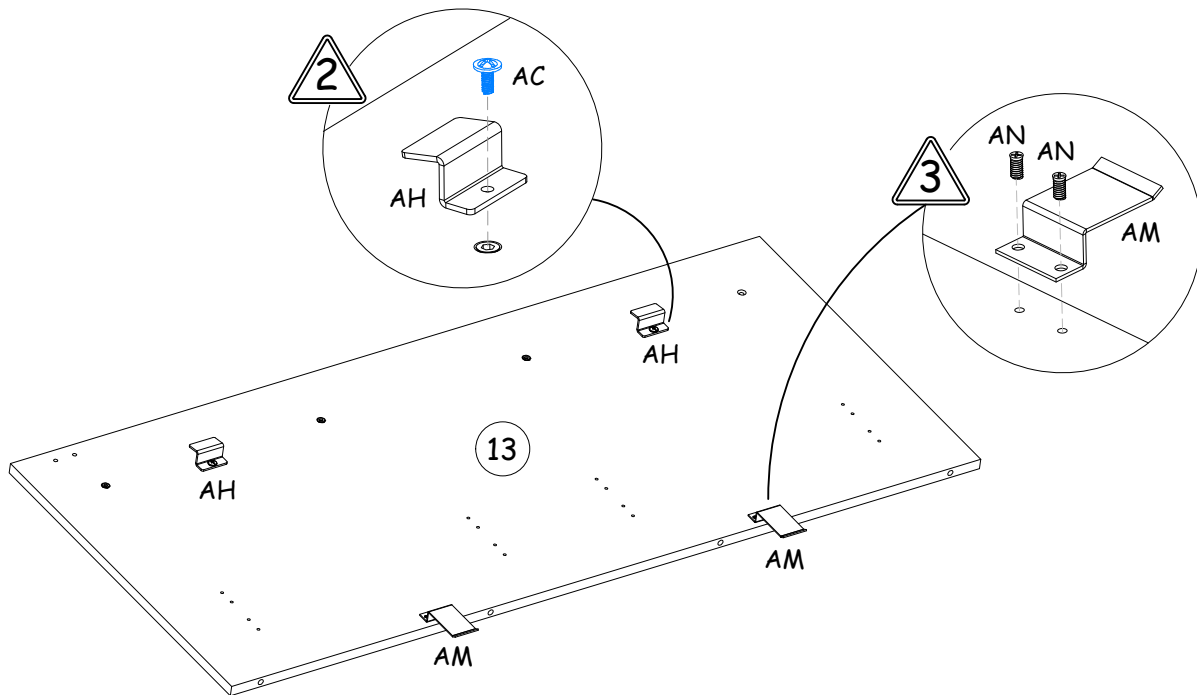

26

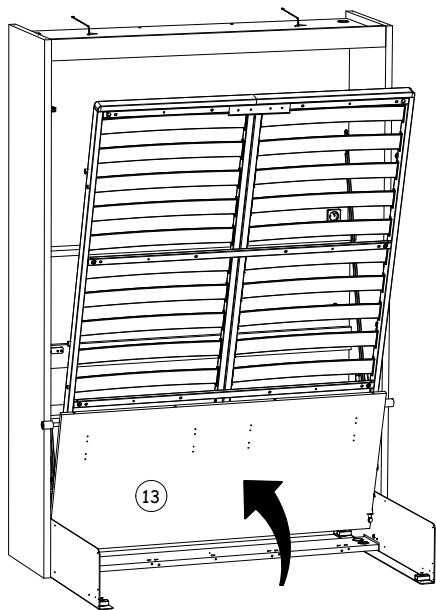

Vue intérieure /
Inside view /
Innenansicht /
Binnenaansicht

Vue de côté /
Side view /
Ansicht von der Seite /
Zijaanzicht

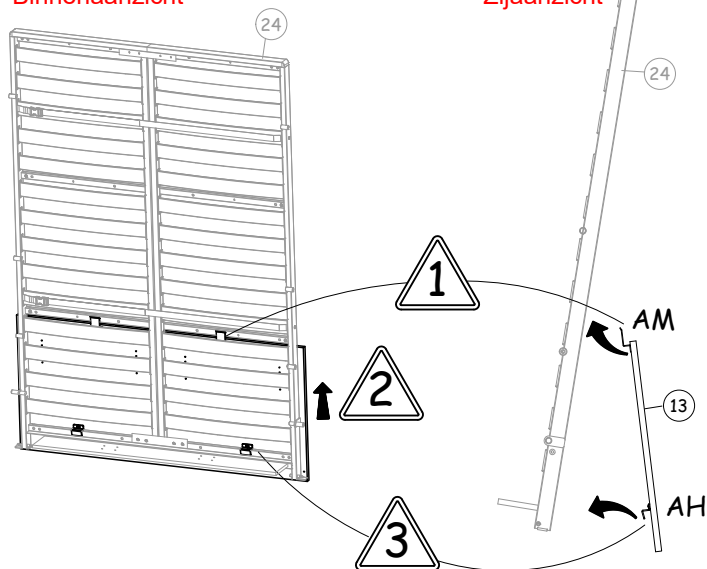

27

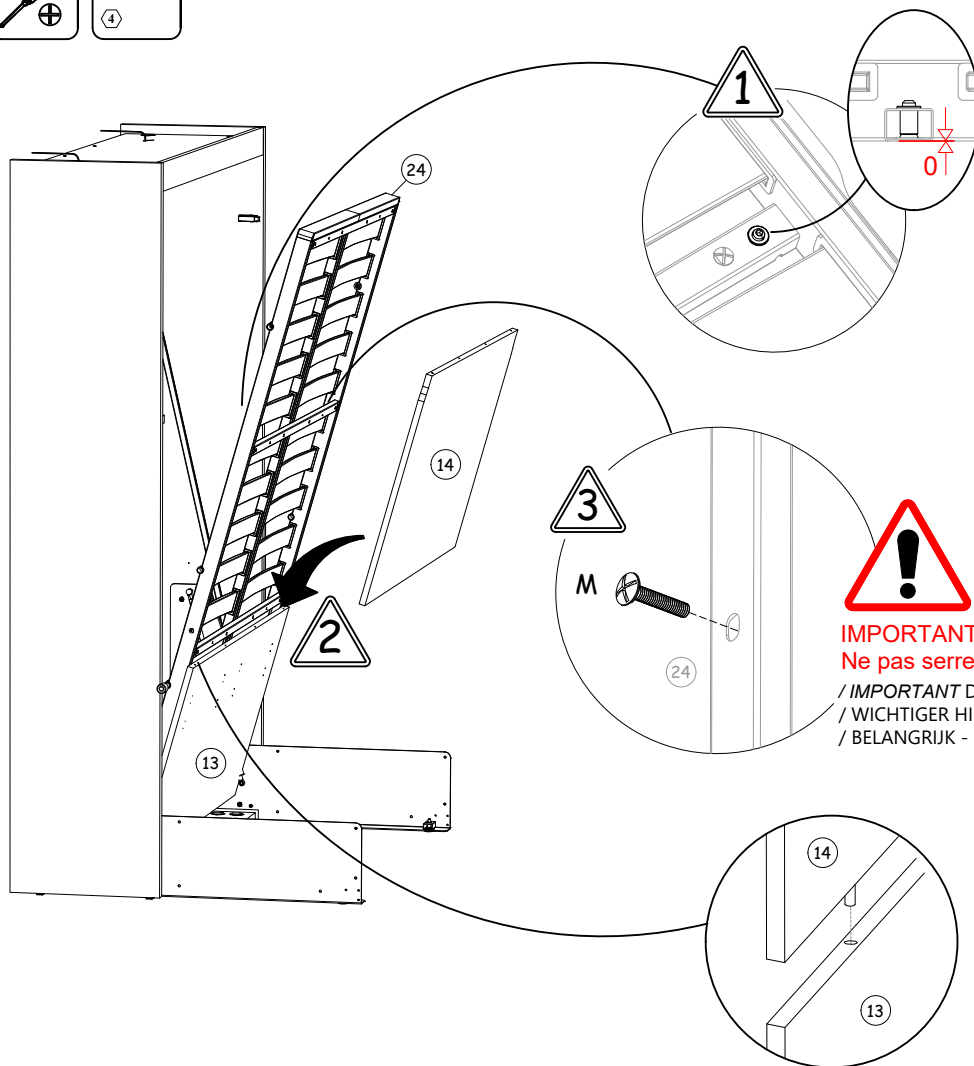
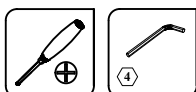

IMPORTANT -
Ne pas serrer entièrement

/ **IMPORTANT** Do not fully tighten.
/ **WICHTIGER HINWEIS** - Nicht vollständig anziehen
/ **BELANGRIJK** - Niet volledig aandraaien

28

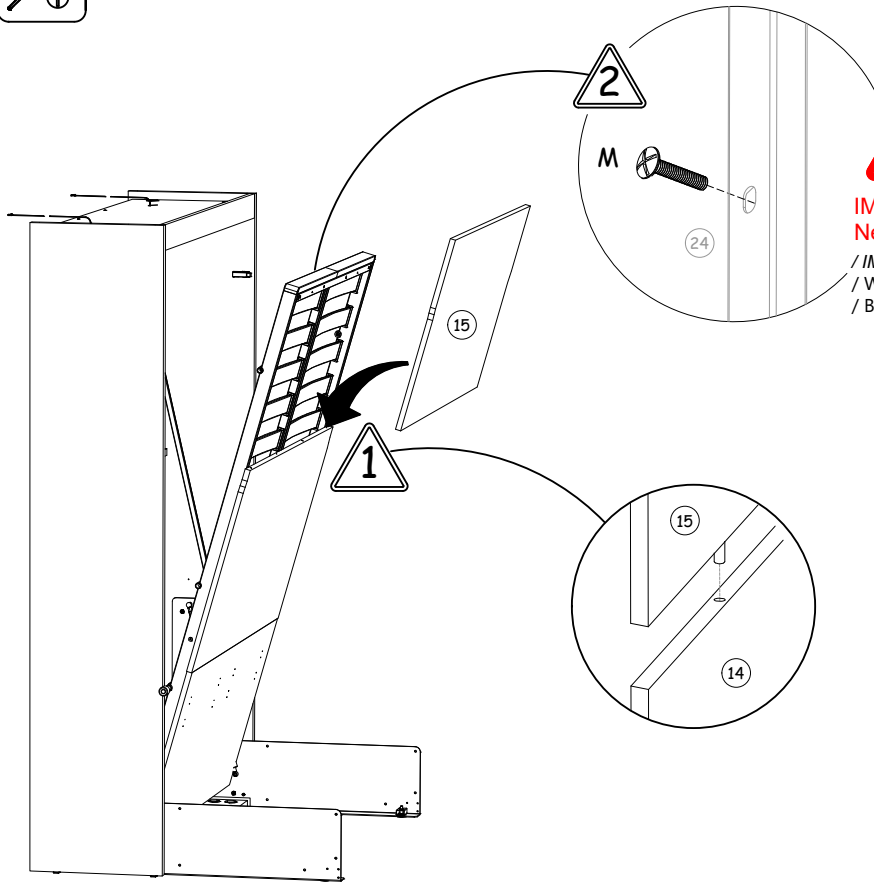

IMPORTANT -
Ne pas serrer entièrement
 / **IMPORTANT** Do not fully tighten.
 / **WICHTIGER HINWEIS** - Nicht vollständig anziehen
 / **BELANGRIJK** - Niet volledig aandraaien

29



A conserver pour réglage ultérieur
 / **Retain for later adjustment**
 / **Für spätere Einstellung aufbewahren**
 / **Te bewaren voor latere afstelling**

BK

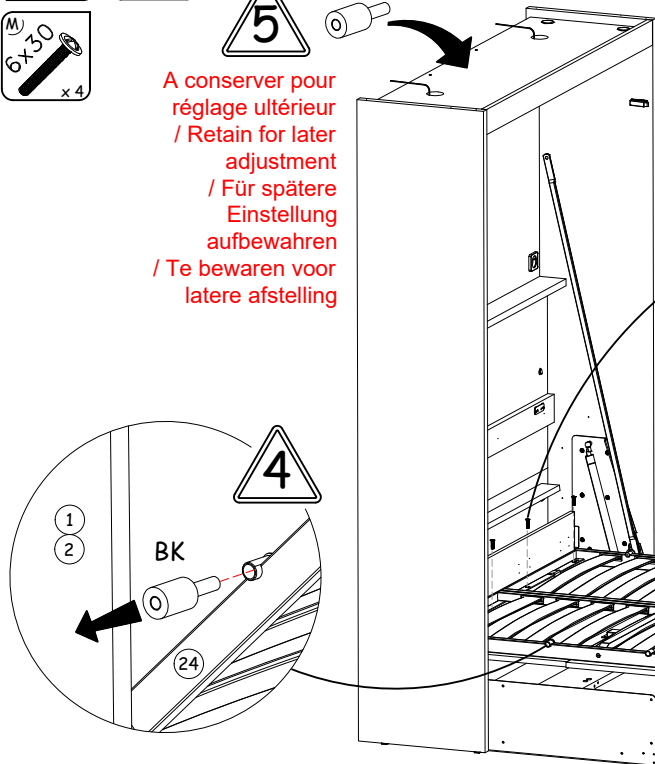

IMPORTANT -
Ne pas serrer entièrement
 / **IMPORTANT** Do not fully tighten.
 / **WICHTIGER HINWEIS** - Nicht vollständig anziehen
 / **BELANGRIJK** - Niet volledig aandraaien

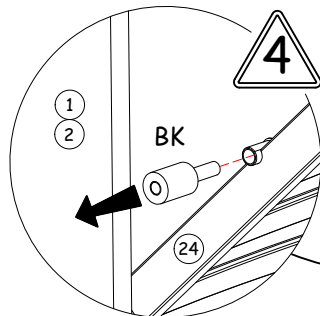

Ajuster (13)(14)(15) et serrer les 16 vis M
 / **Adjust (13)(14)(15) and tighten the 16 crews.**

/ **Einstellen (13)(14)(15), die 16 Schrauben anziehen**
 / **Aanpassen (13)(14)(15), Draai de 16 schroeven aan**



30

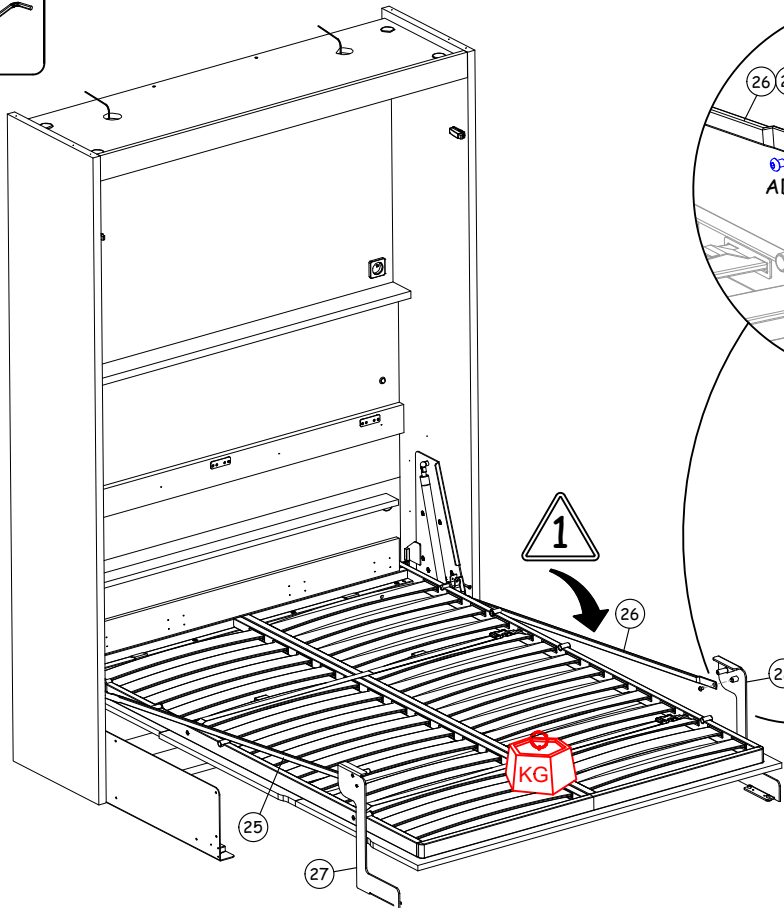
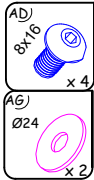

31

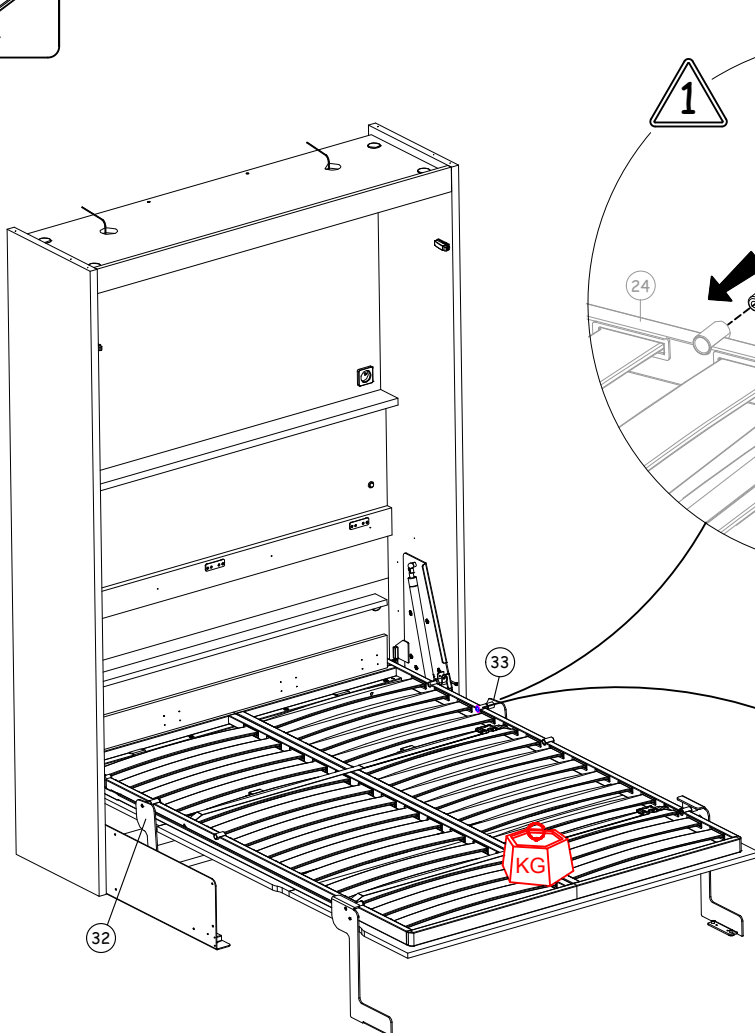

32

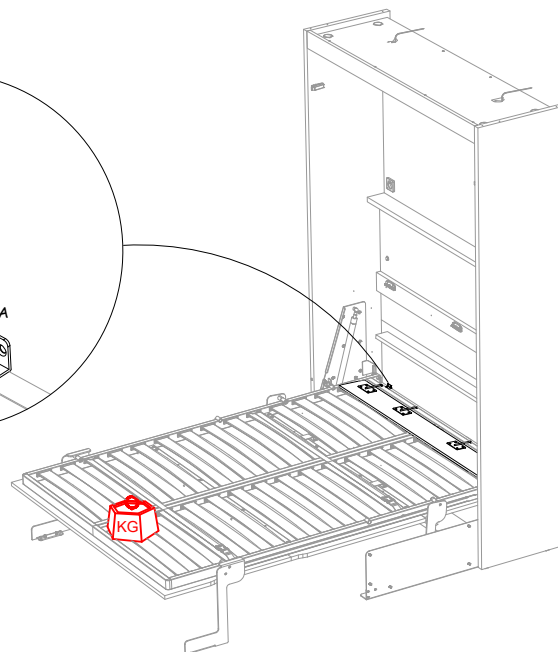
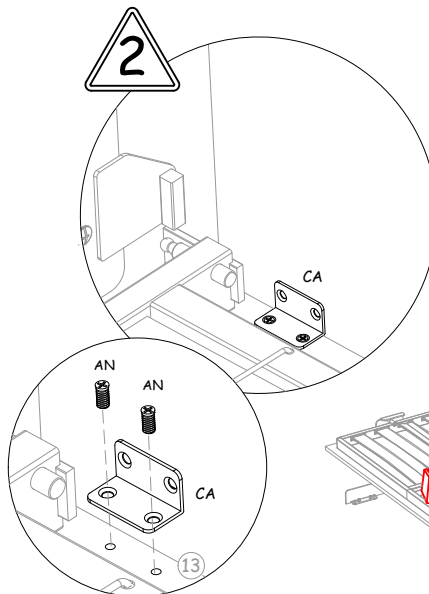
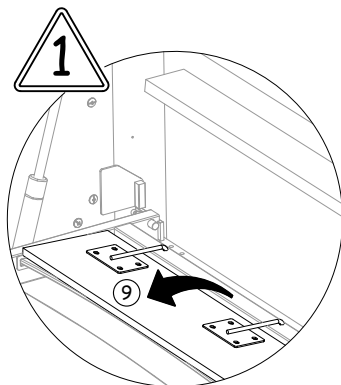

33

Tester le bon fonctionnement de l'éclairage et des interrupteurs /
Testing the correct functioning of the lighting and switches /
Die Funktionsfähigkeit der Beleuchtung und der Schalter testen /
Test of de verlichting en de schakelaars goed werken

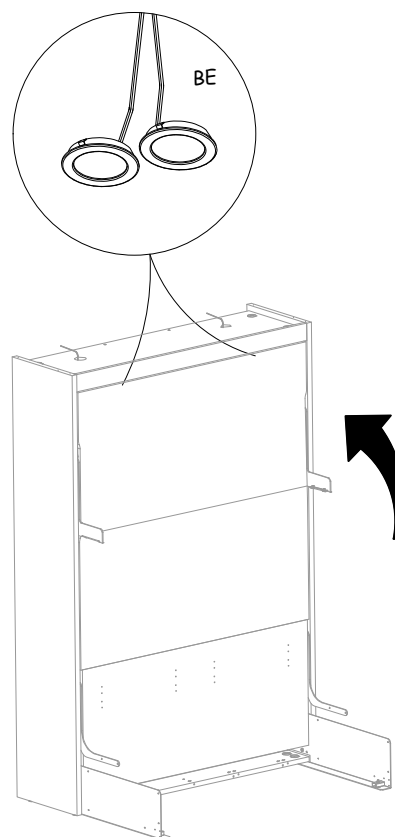
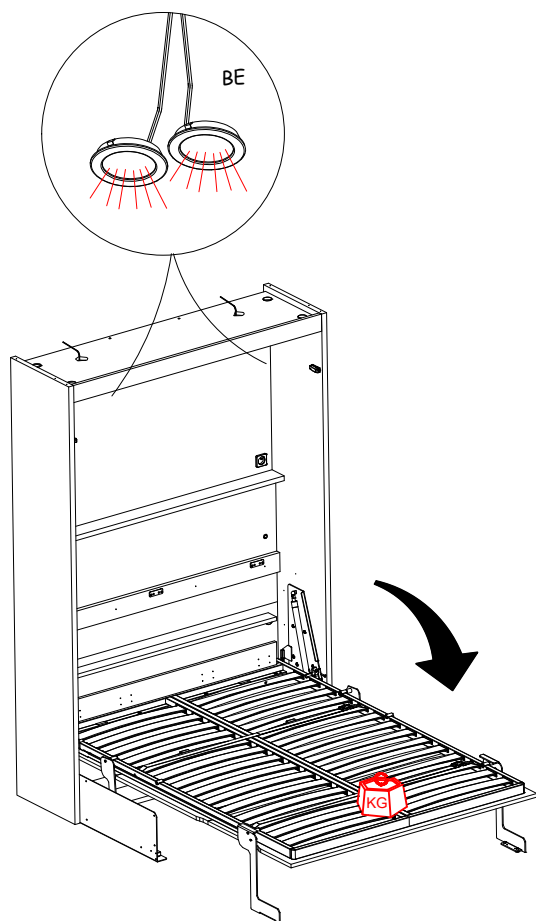

34

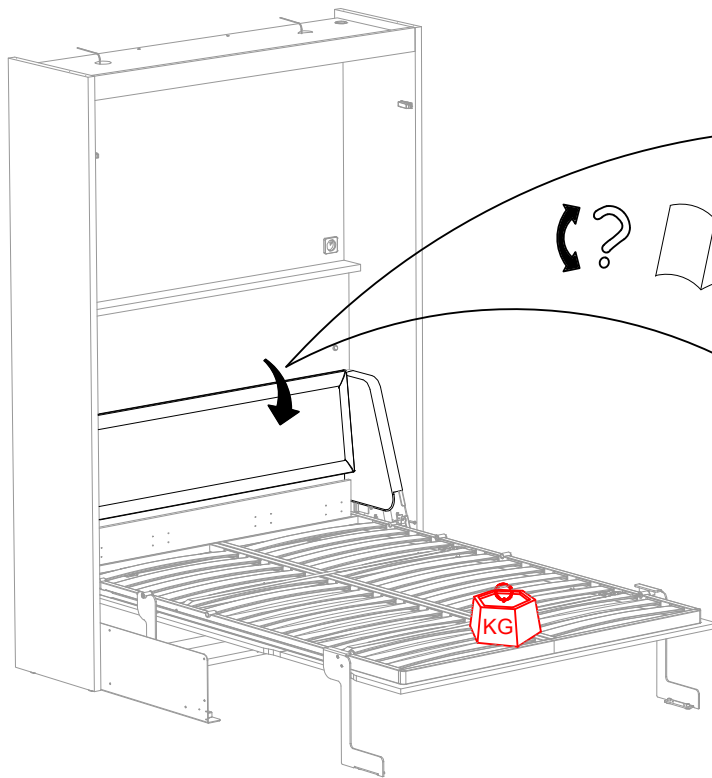

LE06 - Tête tissu

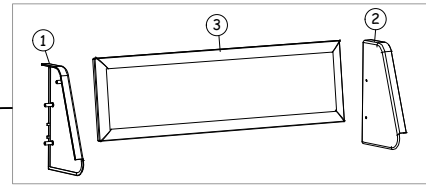

LE05 - Tête bois

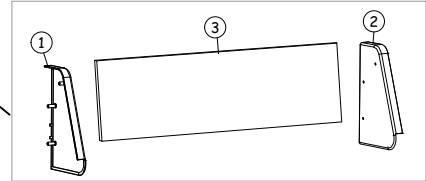

35

Poids du matelas Matress weight Gewicht der Matratzen Gewichten van de matrassen	Mini 23 kg - Maxi 28 kg
Epaisseur MAXIMUM du matelas Maximum thickness of the mattress Maximale Matratzenstärke Maximumdikte van de matras	Maxi 220 mm

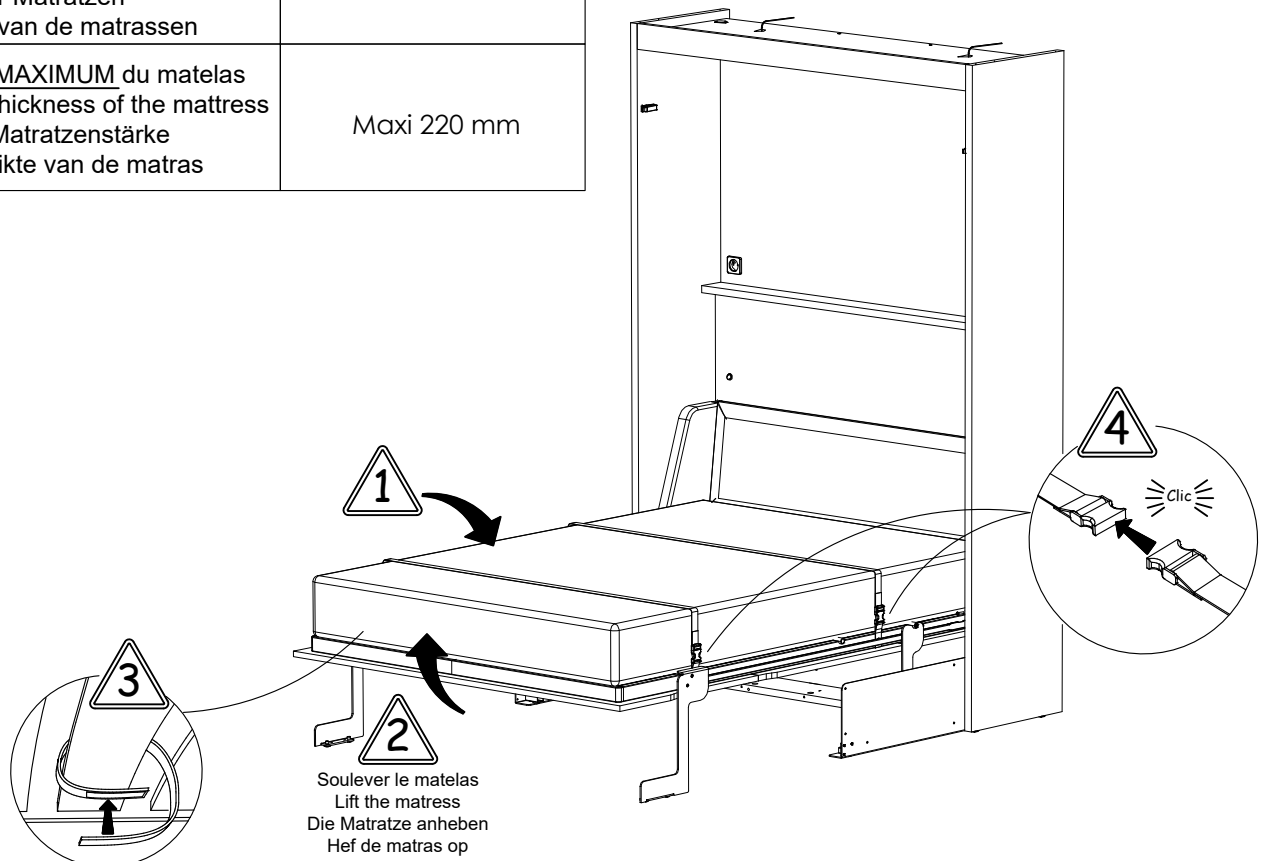

36

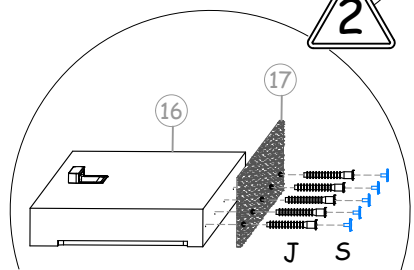
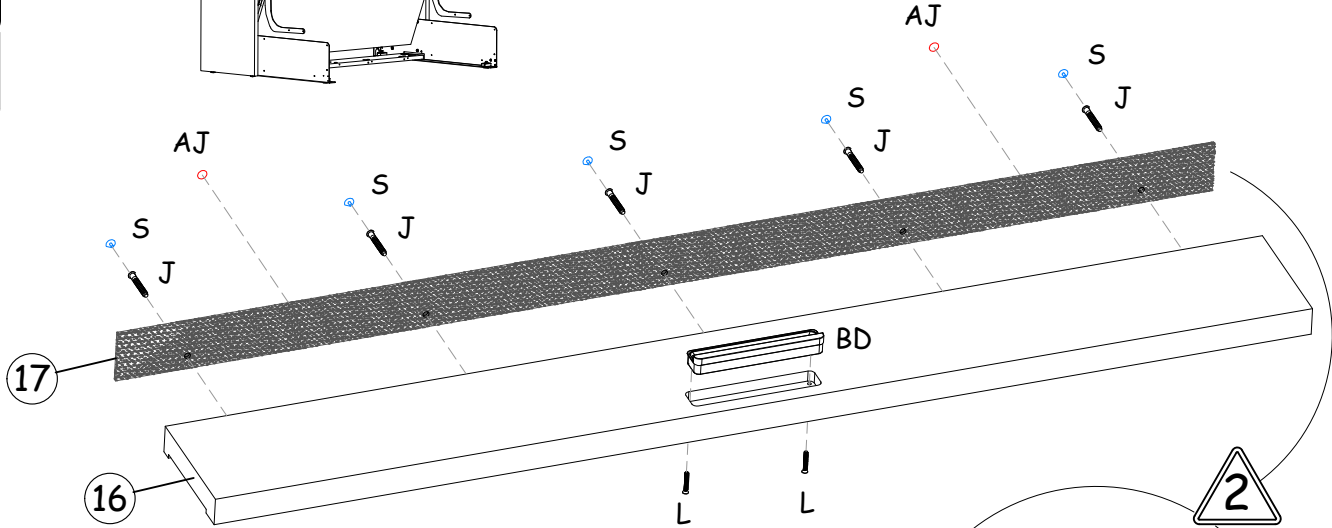
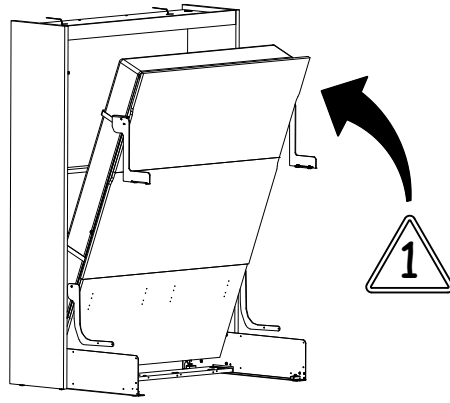

VUE DE COTE /
Side view /
Ansicht von der Seite /
Zijaanzicht

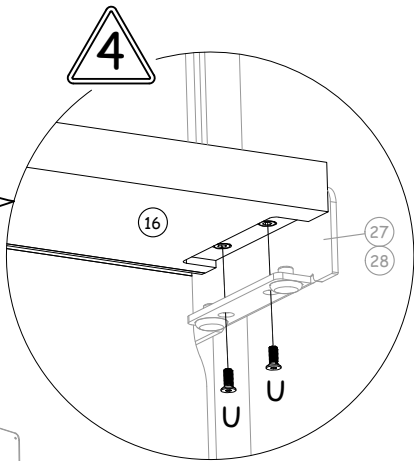
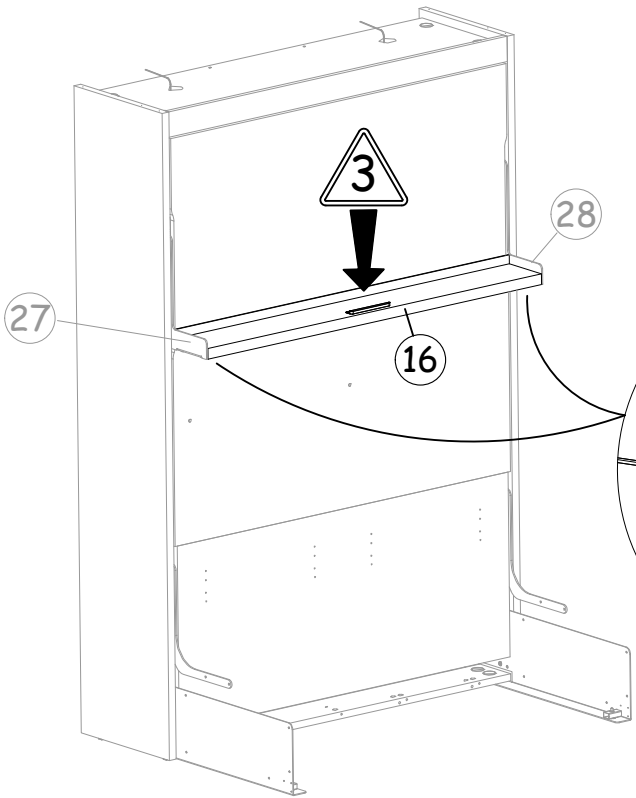
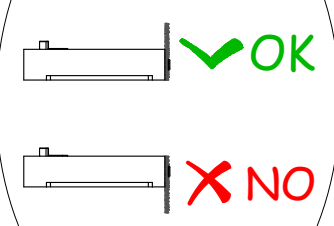

37



- AS 6x10 x 6
- AU 8x30 x 4
- AW x 4
- AZ Ø22 x 8
- AT 8x35 x 4
- AX Ø18 x 4
- BL M6 Ø14 x 6

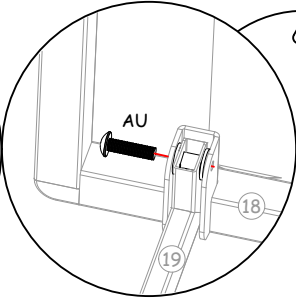
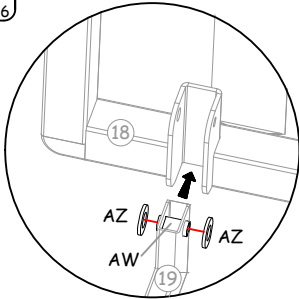
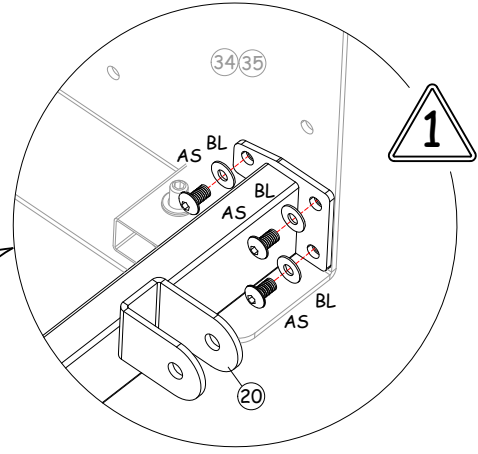
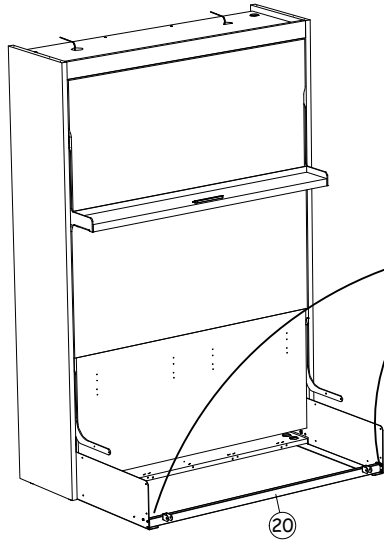

2

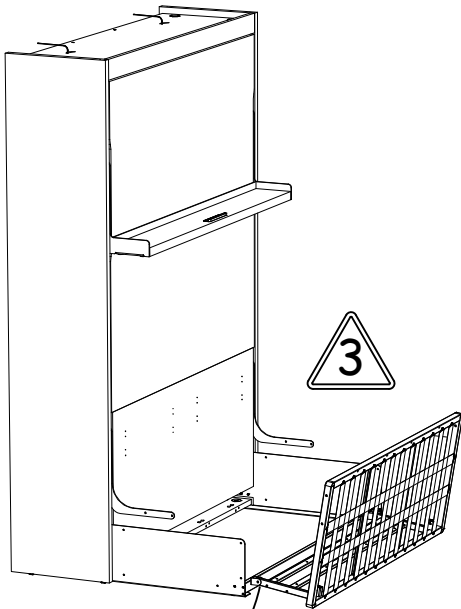
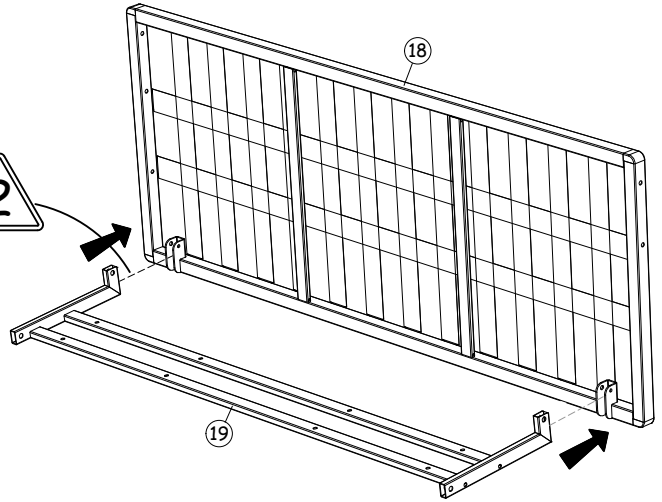

3

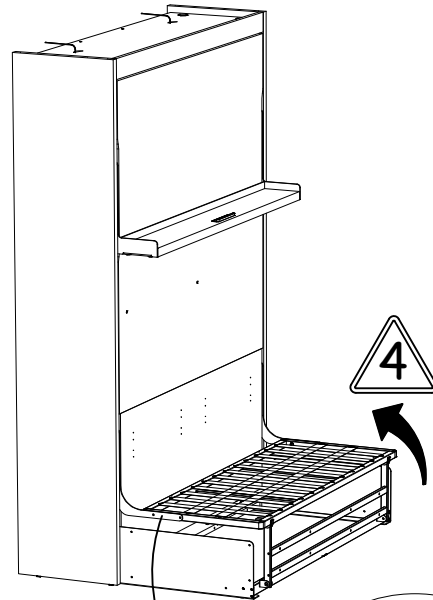
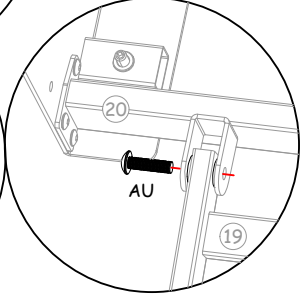
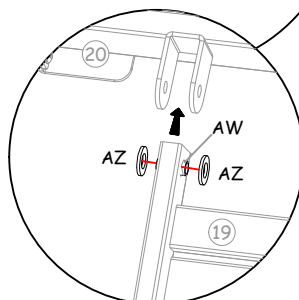

4

5

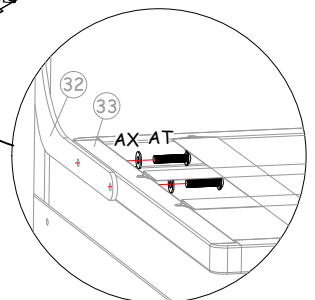

38



✓ OK

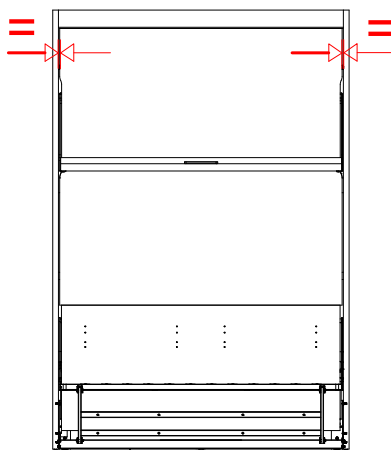

Contrôler / Control
/ Steuerung / Controle



✗ NO

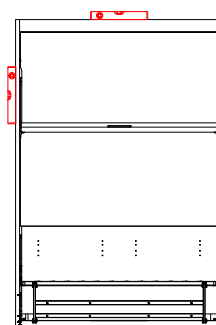
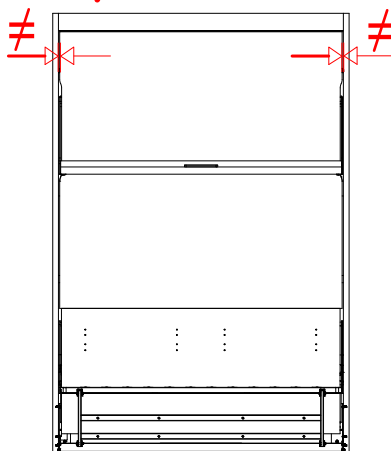

✓ OK

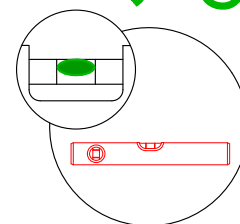

Si le jeu du sommier est inégal,
/ If the gap of the bed base is uneven
/ Wenn das Spalt der Bettbasis ungleichmäßig ist
/ BAls de bedbodem ongelijk is

39

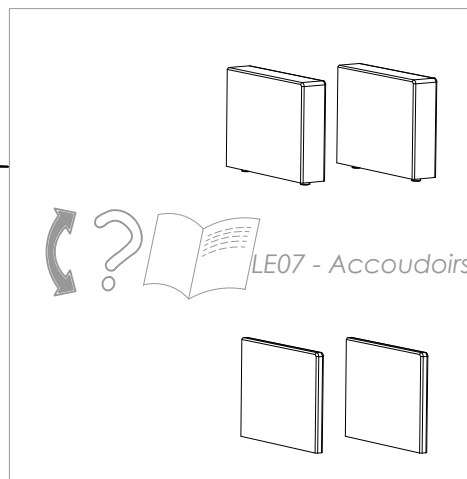
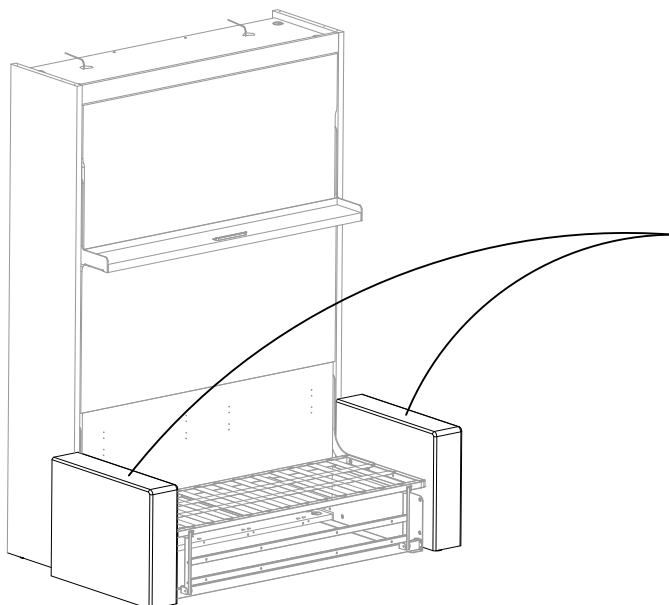

40

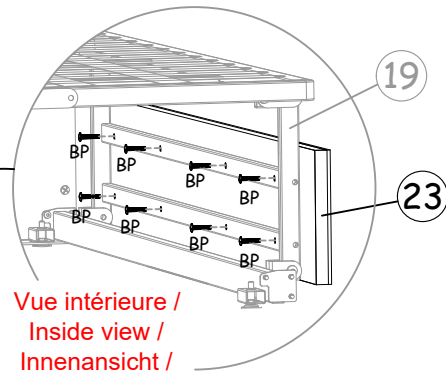
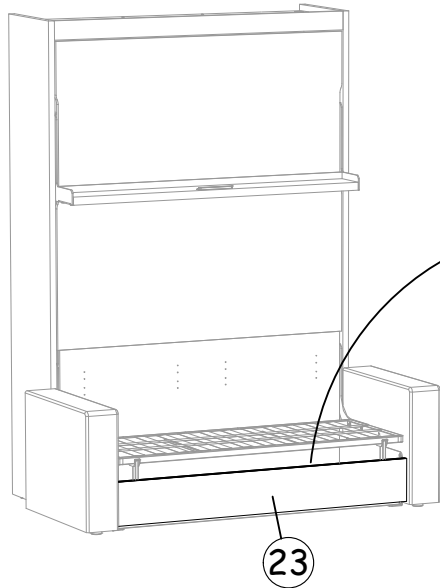

Vue intérieure /
Inside view /
Innenansicht /
Binnenaansicht

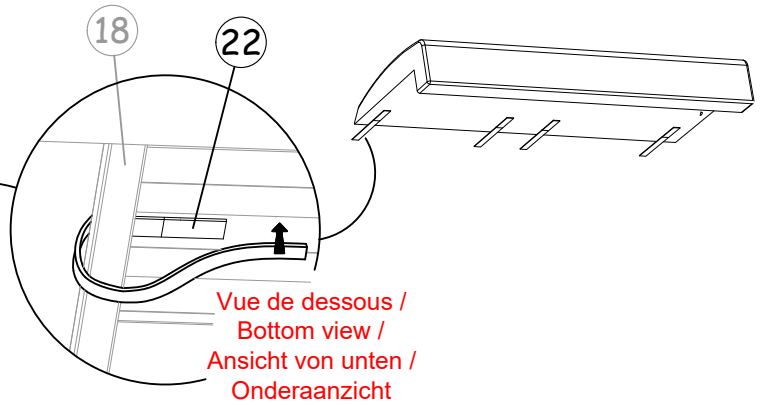
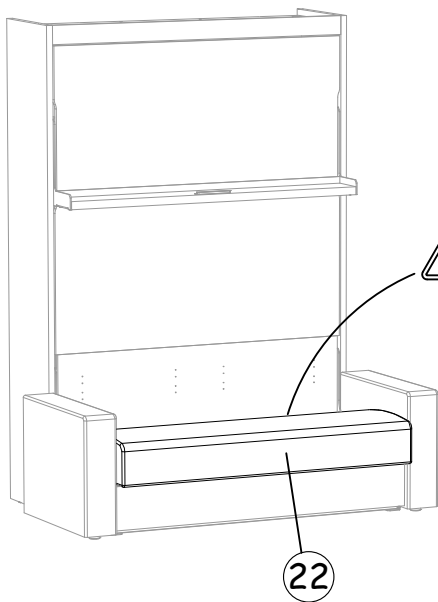

Vue de dessous /
Bottom view /
Ansicht von unten /
Onderaansicht

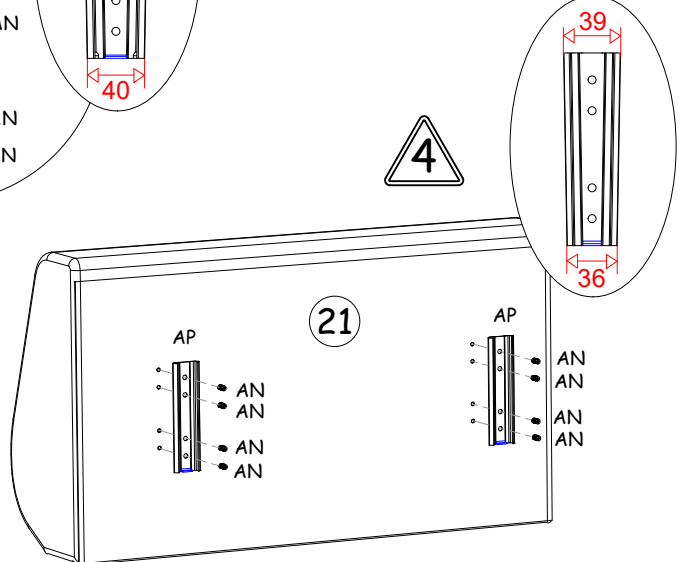
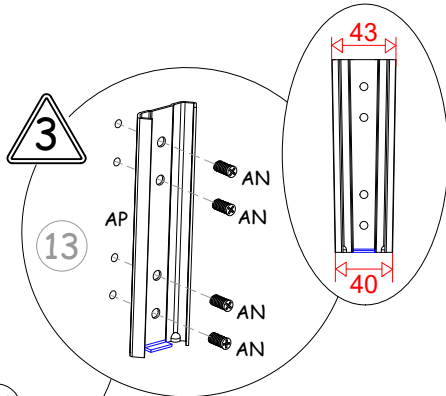
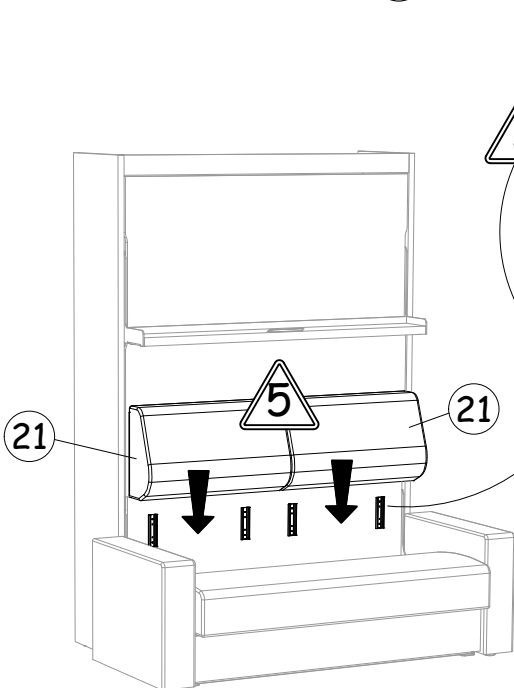

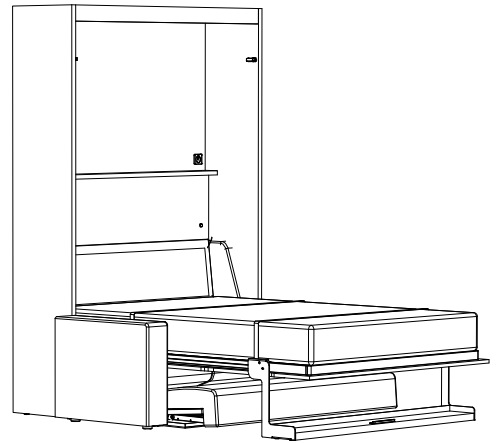
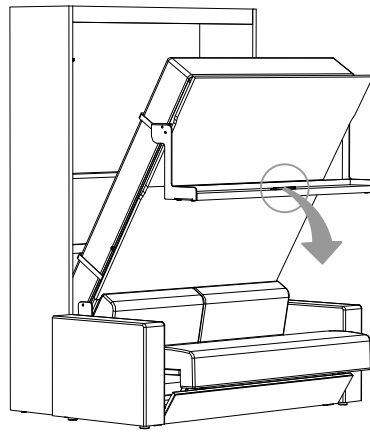
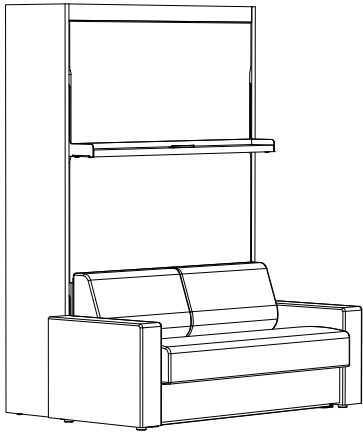

ATTENTION / CAUTION / ACHTUNG / BELANGRIJK!

Charge maximale recommandée, uniformément distribuée :
/ *Maximum recommended load, evenly distributed :*
/ *Maximal empfohlene Traglast (gleichmäßig verteilt):*
/ *Aanbevolen maximale belasting bij gelijkmatige verdeling:*

