

TETIERE - PU ET TISSU

PU and Fabrics Headboard
Kopfteil - PU und Stoff
Hoofdeinde - kunstleer en stof

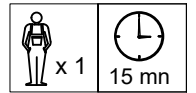
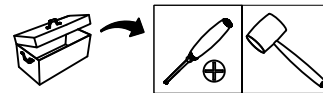
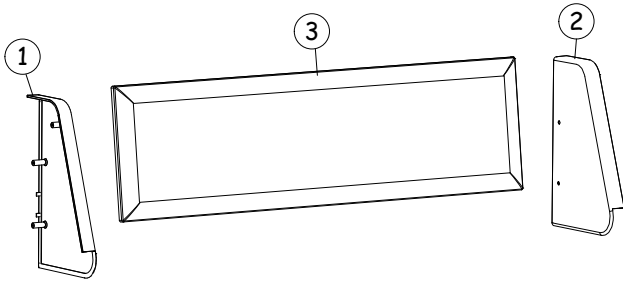
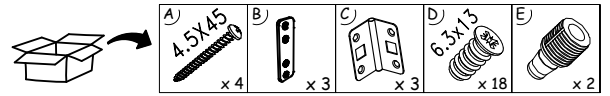
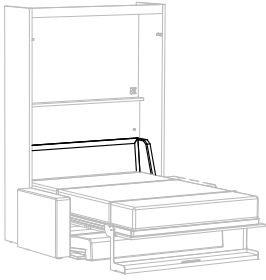

Les cotes indiquées sont en millimètres / Dimensions are given in mm
/ Alle Maße sind in mm angegeben / De opgegeven maten zijn in millimeter

IMPORTANT - A lire attentivement - A conserver
IMPORTANT - Read carefully - keep these instructions
WICHTIGER HINWEIS - Bitte aufmerksam lesen - Bitte aufbewahren
BELANGRIJK - Aandachtig lezen - Goed bewaren

<p>FR</p> <p>CONSEILS DE PREPARATION AU MONTAGE :</p> <ol style="list-style-type: none"> 1 : Repérez les pièces constituant le meuble. 2 : Regrouper et comptez la quincaillerie. 3 : Munissez vous de l'outillage nécessaire. 4 : Aménagez vous une zone de montage ; la moquette ou une couverture protégera des rayures. 5 : Procédez au montage. Ne jamais forcer les assemblages. Resserez les vis après quelques temps d'utilisation. 6 : Gardez votre notice de montage, si une pièce venait à manquer, elle serait le moyen le plus clair pour communiquer avec votre magasin. 7 : Avant de jeter l'emballage, vérifiez s'il est bien vide. 	<p>CONSEILS D'ENTRETIEN :</p> <p>Dépoussiérer avec un chiffon sec et doux. Si besoin, passer une éponge humide, voire légèrement savonneuse, puis essuyer aussitôt avec un chiffon sec, propre et doux.</p> <p>EVITER :</p> <p>Les solvants, diluants, alcools, abrasifs et cire.</p> <p>NOTA : En cas de doute, faire un essai sur une partie peu visible du meuble.</p> <p>ATTENTION :</p> <p>Ne pas utiliser de produit ammoniacal pour le nettoyage des miroirs, et surtout éviter que le produit ne coule à l'extérieur.</p>
--	--

<p>GB</p> <p>PREPARATION ADVICE BEFORE ASSEMBLY :</p> <ol style="list-style-type: none"> 1 : Identify each part of the unit and where it goes before you start assembling. 2 : Keep all metal screws, fixtures and fittings in a box and check that you have the right quantity. 3 : Make sure you have all the tools you need. 4 : Prepare an assembly area: spread out a sheet or rug to stop panels getting scratched. 5 : Start assembly. Never force any components when assembling. Check screws from time to time and retighten if necessary. 6 : Keep this instruction booklet for future reference. It's the most useful way of identifying a missing part. 7 : Check that packaging is empty before throwing it away. 	<p>CARE INSTRUCTIONS:</p> <p>Clean using a soft, dry cloth. If necessary, clean with a damp sponge and slightly soapy water, then dry immediately with a soft, clean, dry cloth.</p> <p>DO NOT USE:</p> <p>Abrasive cloths, solvents, thinners, alcohol-based products or any other chemical solvents, and waxes.</p> <p>It is best to test any cleaning products on a small area first.</p> <p>WARNING:</p> <p>Do not use ammonia or ammonia-based products to clean mirrors. Do not let mirror-cleaner come into contact with any other part of the unit.</p>
--	--

<p>DE</p> <p>TIPPS ZUR VORBEREITUNG DER MONTAGE :</p> <ol style="list-style-type: none"> 1 : Verschaffen Sie sich einen Überblick über die mitgelieferten Teile. 2 : Überprüfen Sie die mitgelieferten Schrauben und Beschläge auf Vollständigkeit. 3 : Legen Sie passendes Werkzeug bereit. 4 : Richten Sie sich einen Platz für die Montage ein. Ein Teppich oder eine Decke schützt vor Kratzern. 5 : Beginnen Sie mit der Montage. Fügen Sie die Teile niemals gewaltsam zusammen. Ziehen Sie die Schrauben nach einiger Zeit nach. 6 : Bewahren Sie Ihre Montageanleitung auf. Sollte ein Teil fehlen, kann Ihnen diese beim Kontakt mit dem Kundenservice helfen. 7 : Vergewissern Sie sich, dass sich keine Teile mehr in der Verpackung befinden, bevor Sie sie entsorgen. 	<p>PFLEGEHINWEISE:</p> <p>Entfernen Sie Staub mit einem trockenen und weichen Tuch. Verwenden Sie bei Bedarf einen feuchten Schwamm mit einer milden Seifenlauge. Wischen Sie die Fläche nach der Reinigung sofort mit einem trockenen, sauberen und weichen Tuch nach.</p> <p>BITTE VERMEIDEN SIE:</p> <p>Abrasive Lösungsmittel, Verdünner, Alkohole und Wachs.</p> <p>HINWEIS: Sollten Sie Zweifel haben, testen Sie das Reinigungsmittel an einer unauffälligen Stelle.</p> <p>ACHTUNG:</p> <p>Bitte verwenden Sie für die Reinigung von Spiegelflächen keine ammoniakhaltigen Reinigungsmittel und achten Sie besonders darauf, dass das Mittel nicht mit anderen Teilen in Berührung kommt.</p>
---	--

<p>NL</p> <p>ADVIEZEN BIJ DE VOORBEREIDING VAN DE MONTAGE:</p> <ol style="list-style-type: none"> 1. Controleer of alle elementen van het meubel aanwezig zijn. 2. Verzamel en tel het beslag. 3. Zorg dat u het nodige gereedschap bij de hand heeft. 4. Maak een montagezone vrij. Gebruik de vloerbedekking of een deken om krassen te voorkomen. 5. Begin met de montage. Bij het assembleren nooit forceren. Draai de schroeven opnieuw aan nadat het meubel enige tijd in gebruik is. 6. Bewaar de montagehandleiding goed. Indien er een onderdeel ontbreekt, komt ze goed van pas om duidelijk met de winkel te communiceren. 7. Gooi de verpakking pas weg als u zeker weet dat ze leeg is. 	<p>ONDERHOUD:</p> <p>Afstoffen met een droge, zachte doek. Wrijf indien nodig schoon met een vochtige spons, eventueel met wat zeep, vervolgens meteen droogwrijven met een zachte, schone en droge doek.</p> <p>VERMIJD:</p> <p>Solventen, oplosmiddelen, schuurmiddelen op alcoholbasis en was.</p> <p>NB: Twijfelt u, test dan eerst op een weinig zichtbaar deel van het meubel.</p> <p>BELANGRIJK:</p> <p>Gebruik geen producten op ammoniakbasis om spiegels schoon te maken en vermijd absoluut dat het product naar buiten lekt.</p>
---	---

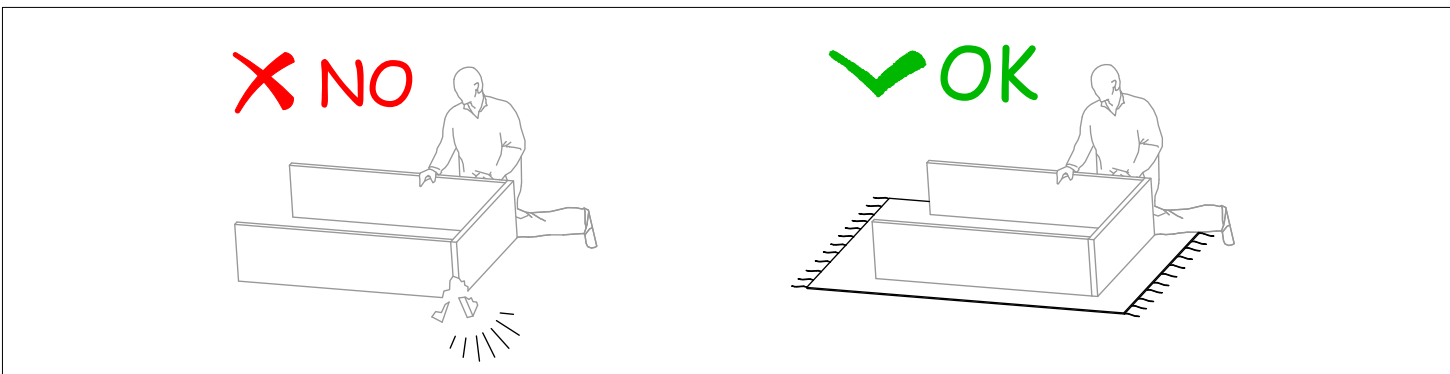

1

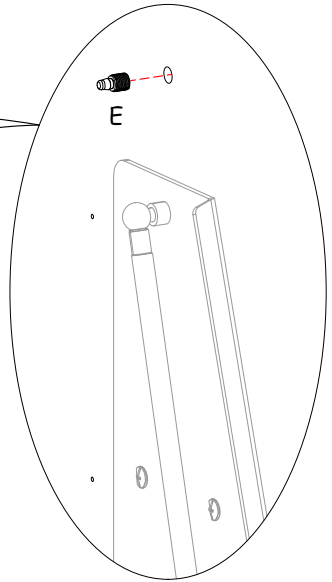
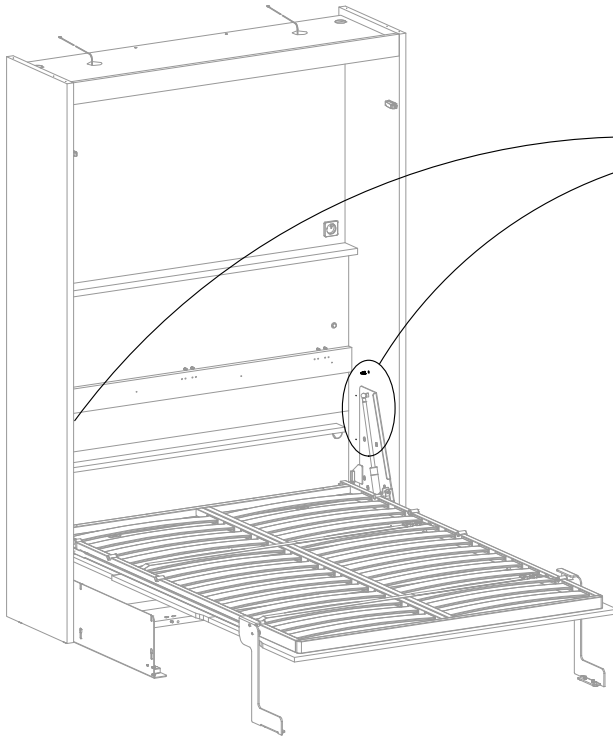

2

