

SYSTEME D'ENTRAINEMENT

A OUTILS



B CONTENU

Vue d'ensemble

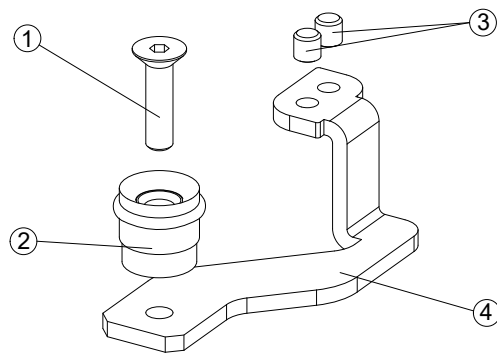
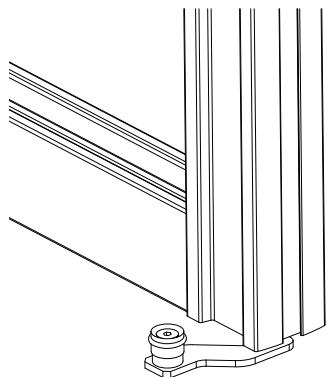

Référence	Désignation	Quantité
1	Vis FHC M4x16	1
2	Patin de guidage	1
3	Vis sans tête M4x4	2
4	Support métallique	1

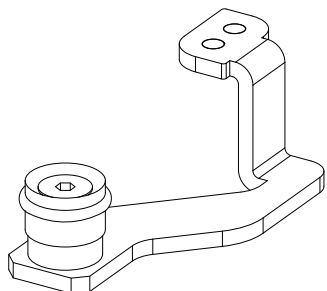

1 MISE EN PLACE DU SUPPORT METALLIQUE DANS LE REDUCTEUR DE GUIDAGE

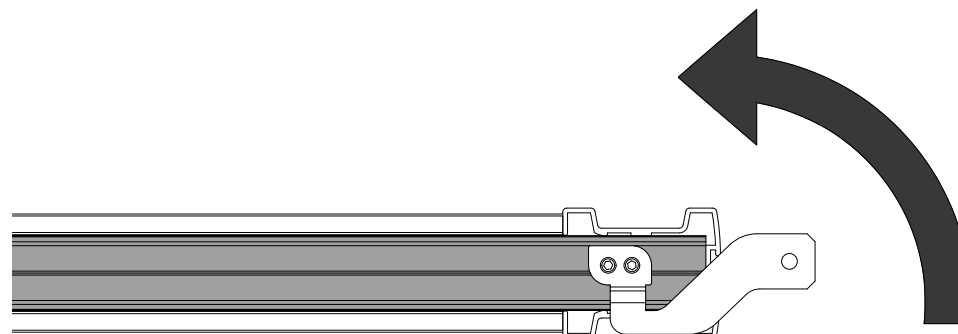
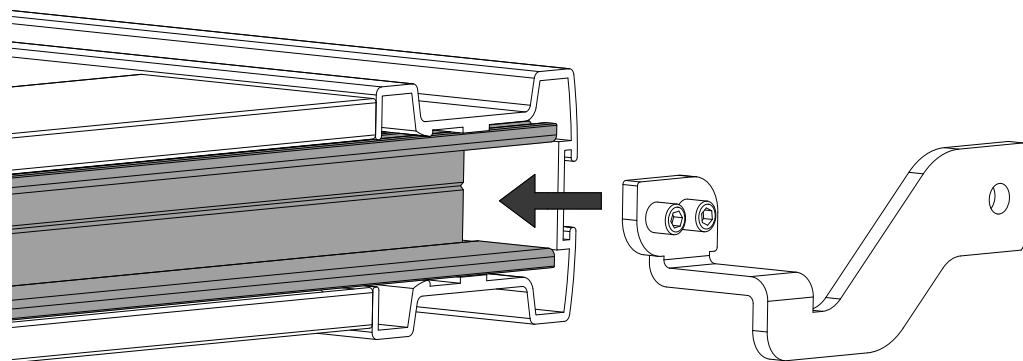

2 POSITIONNER LE SUPPORT METALLIQUE

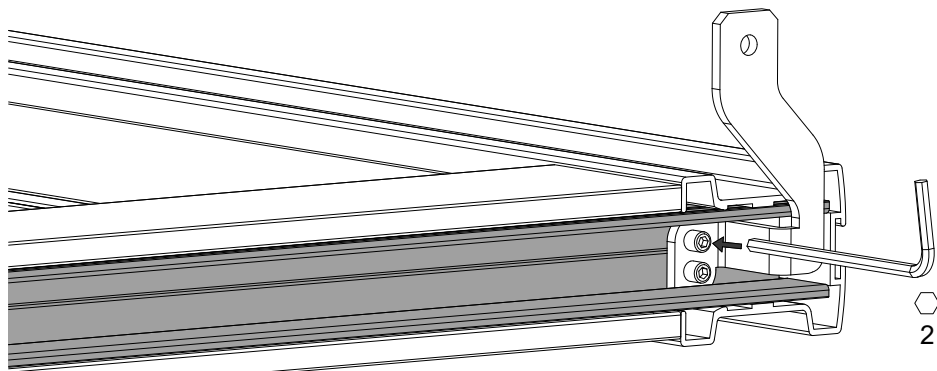
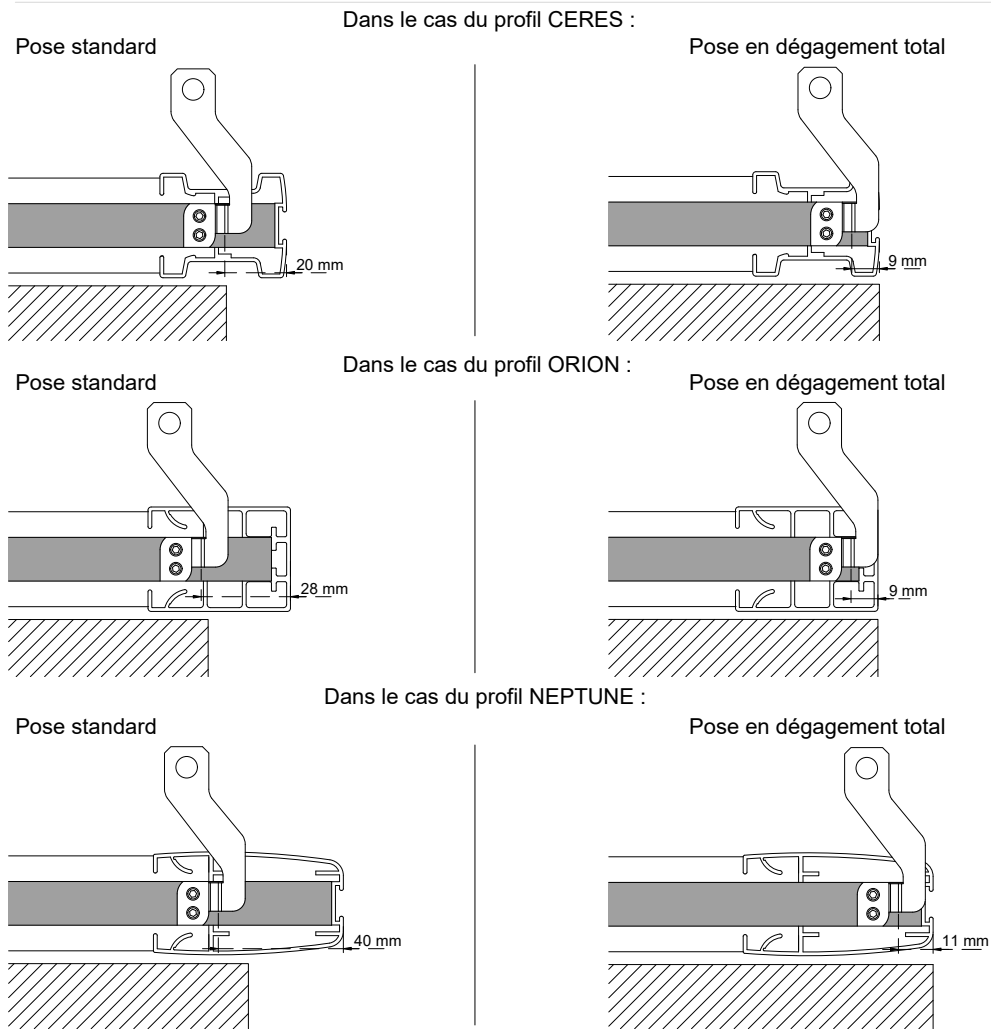

3 FIXER LE PATIN DE GUIDAGE

